

Contact

Andrea Trautmann
Marketing Communications
Coperion GmbH
Niederbieger Str. 9
88250 Weingarten / Germany

Telephone +49 (0)751 408 578
Fax: +49 (0) 751 408 99 578
andrea.trautmann@coperion.com
www.coperion.com

Press Release

Suitable for a variety of discharge applications in bulk material handling:

New Coperion Compact Design FFU Universal Gate Valve

Stuttgart, September 2024 – Coperion has developed a new discharge gate valve for controlled bulk material flow from storage bins and hoppers to downstream process steps. This valve is suited for a variety of applications in the chemical and plastics industries with its impressively compact yet very robust construction. One particular feature of this new discharge valve is that it closes securely and reliably while material is flowing, but usually also when the product column is stationary, making this a perfectly suited gate valve for demanding applications. This new valve that is well thought out in design and construction secures operators a singularly reliable technology solution and makes installation and maintenance simple.

Latest manufacturing technology enables compact design

Coperion manufactures this discharge valve using a precision casting process, enabling its compact and lightweight design. Its intelligent geometry, select guide elements and the form of the seal ensure that the FFU universal gate valve can be used for a wide variety of applications with the most diverse demands — even in combustible areas (ATEX). This new geometry is what allows the gate valve to be used in the usual way even when the bulk material is stationary and best of all, its high-quality, robust construction ensures dependable operation over time. Various models with manual or pneumatic drive are available in sizes DN 150 to 400 (6 to 16 inches) and can be implemented in a variety of customer-specific options.

“Decades of experience in handling a variety of bulk materials, comprehensive expertise in plant construction, and years-long partnerships with our customers allows us to develop new products

September 2024

that are precisely tailored to customer needs. With the new Coperion FFU universal gate valve, we offer a simple, cost-effective and flexible solution for numerous discharge applications in a variety of industries,” said Markus Reinke, Head of Component Sales at Coperion in Weingarten.

About Coperion

Coperion (www.coperion.com) is a global industry and technology leader in compounding and extrusion systems, size reduction, washing, separating, drying, and agglomeration, feeding, weighing, material handling and pneumatic conveying systems, as well as milling, mixing, thermal processing, dust collection and other services. Coperion develops, produces, and services plants, machinery, and components for the plastics and plastics recycling, chemical, battery, minerals, food and pharmaceutical industries. Coperion employs more than 5,000 people in its three divisions, Polymer, Food, Health & Nutrition, and Aftermarket Sales & Service - at over 50 sales and service locations worldwide. Coperion is an Operating Company of Hillenbrand (NYSE: HI), a global industrial company that provides highly-engineered, mission-critical processing equipment and solutions to customers serving a wide variety of industries around the world. www.hillenbrand.com

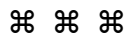

Dear Colleagues,

You can find and download this press release in German and English and print-ready color images at

<https://www.coperion.com/en/news-media/newsroom/>

Editorial contact and copies:

Dr. Jörg Wolters, KONSENS Public Relations GmbH & Co. KG,
Hans-Böckler-Str. 20, D - 63811 Stockstadt am Main, GERMANY
Tel.: +49 (0)60 27/ 99 00 5-0
E-Mail: mail@konsens.de, Internet: www.konsens.de

September 2024

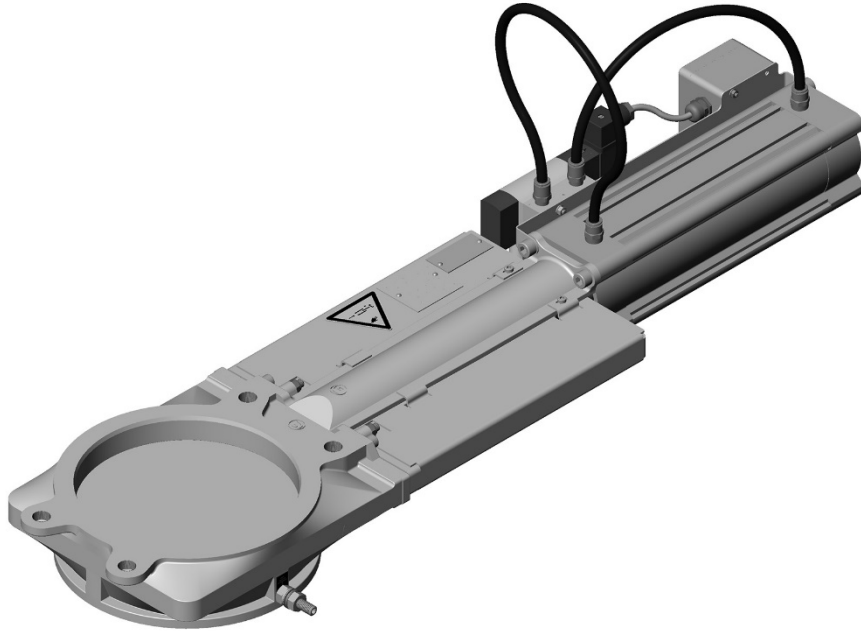

The recently developed FFU universal gate valve is suited for a variety of discharge applications in myriad industries, boasting a compact yet very robust construction as well as the ability to close when product is stationary.

Photo: Coperion, Weingarten/Germany