



Innovative Feeding and Material Handling Solutions for Food and Pet Food Processing

Innovative Material Handling Solutions

Single Source Solution

Coperion K-Tron can provide single source solutions for all your feeding and conveying needs in the food and pet food industries. A variety of designs and equipment executions are available, dependent upon the specific needs and sanitary design requirements of the application. FDA approved materials of construction are standard,

with all units specifically designed to meet the cleaning requirements of the end-user. Design options include complete wash in place and rinse in place cleaning as well as standard designs for air pressure cleaning.

All equipment in both the feeder lines as well as the pneumatic conveying lines are designed to provide ac-

cessability and ease in maintenance. Executions are available for use in hazardous environments according to both ATEX and NEC guidelines. Both the Coperion K-Tron line of feeders and the Coperion K-Tron line of pneumatic conveying equipment are reliable industry "workhorses" with many installations in continuous use for over 30 years.

Systems Design and Integration

Coperion K-Tron's System Engineering Group specializes in supplying systems focused on material transfer and process ingredient feeding on a worldwide basis. Whether it is process conversion from batch to continuous, from railcar and silo unloading all the way to the extrusion, mixing or packaging process, Coperion K-Tron's experienced technical engineers are available to discuss your applications in detail. Standard packages include recommendations on specific design options for process and margin optimization, with minimization of production downtime due to cleaning or product change-over. Considerable savings on overall process costs as well as improvement in process quality can be easily achieved by consultation with our systems design experts.

Control Integration

Coperion K-Tron can provide a variety of control options to meet your process needs. As shown in the side bar, Coperion K-Tron offers a variety of user interface options for both the feeders as well as the pneumatic conveying systems. In addition, Coperion K-Tron's systems engineering group can provide custom PLC based control systems in a variety of control platforms such as Siemens and Allen Bradley.

Typical Food Applications

- › Continuous Extrusion for Snack Foods, Pet Foods, Pasta Processing
- › Continuous and Batch Blending of Multiple Ingredients
- › Vacuum Coating Processes
- › Bulk Unloading and Storage
- › Coating Drum, Seasoning, and Spicing Processes
- › Major, Minor and Micro Ingredient Transfer and Batch Weighing

Coperion K-Tron offers complete solutions from material pickup to process

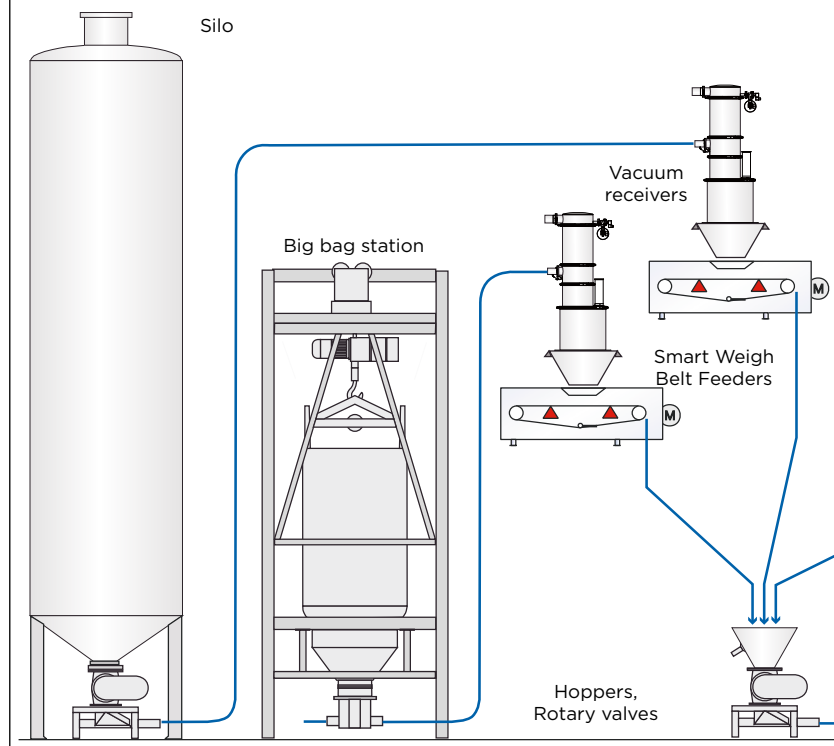



Coperion K-Tron feeders and vacuum conveyors in a continuous food process

SmartConnex Control Options

The Coperion K-Tron Control Module (KCM) combines feeder control and motor drive modules into a compact new housing, offering more flexibility and excellent performance. Each feeder has its own KCM, generally mounted directly on the feeder, which comes with all the software needed for continuous or batch applications. Connection between feeders and operator interface is via a network. The KCM can also connect directly to the plant's automation network. A variety of communication protocols are available, including: Modbus, Ethernet/IP, DeviceNet Profibus etc.



SmartConnex offers a choice of four operator interfaces to display and enter data, which can be employed individually or in combination as demanded by the application.

➤ **KSU-II Single Unit Interface** - The KSU-II is an economical user interface for single feeders with KCM. It can also be used as a portable display for maintenance or configuration in larger systems where the feeder's primary display point is a higher level unit. The KSU-II will only view one feeder at a time, but the user can switch between feeders.

➤ **K-Vision Line Controller** - The K-Vision™ operator interface simultaneously controls up to 16 feeders in one line via an easy to use color LCD touchscreen. K-Vision provides recipe entry and a detailed overview of the process line with extensive real-time monitoring of feeder status and performance in a choice of seven languages. A wide range of easily configured charting and trending capabilities are also included.



➤ **KSC Smart Commander** - The KSC is a PC-based interface, able to control up to 30 feeders in multiple process lines. Feeder, vacuum receiver, line and system-wide data is graphically displayed and includes historical trends, statistical control, recipe commands, diagnostics, help, and much more.

➤ **Series 4 MPC Controller** - The Coperion K-Tron Series 4 Microprocessor Controller is a central user interface for controlling up to 24 vacuum receivers on one blower. The Series 4 MPC features an easy-to-use, touch-sensitive keypad and can easily be integrated into Coperion K-Tron SmartConnex feeder controls.

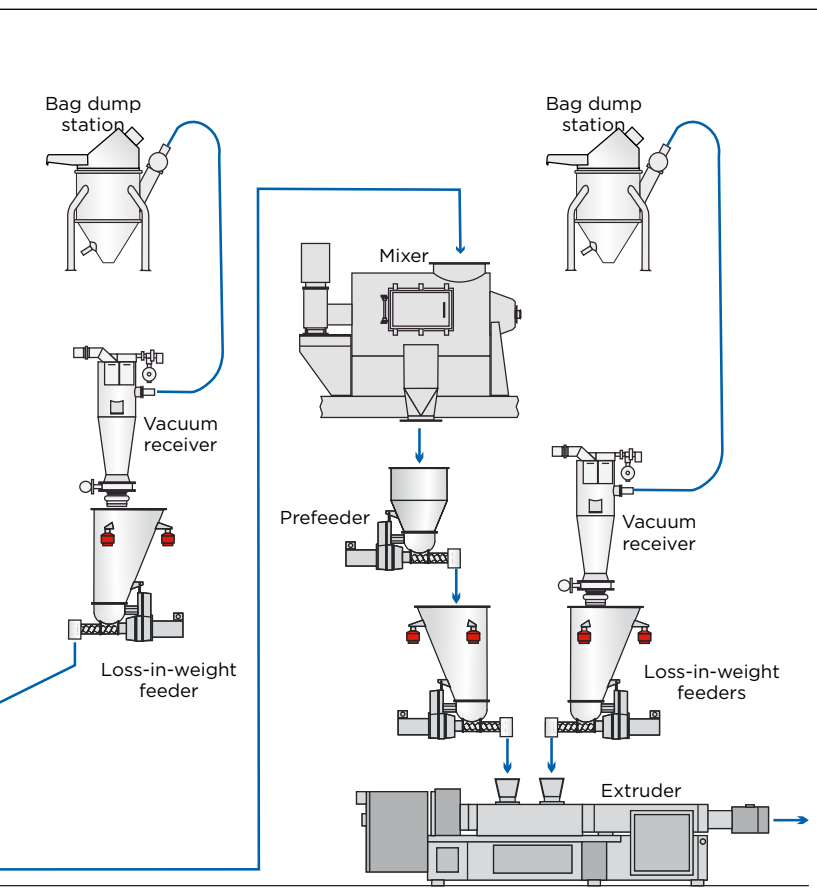

Innovative Feeding Solutions

Feeding Solutions for Food Applications

Thousands of Coperion K-Tron feeders have been sold for a variety of food applications. Coperion K-Tron feeders specialize in the high accuracy addition of high value minor and micro ingredients to the batch or continuous process. Feeders can be used for both dry ingredients as well as liquid flavors and additives. Typical food type materials include cereals and breakfast foods, snack foods, pet/fish foods and feed, confectionary/chocolate products, coffee, flour/dough/bakery products, probiotics, trace elements, vitamin fortifiers, liquid flavors and aromatics. Volumetric and loss-in-weight feeders operate in accordance with the principles outlined on the sidebar for continuous proportioning to the downstream process. Processes such as extrusion, mixing, and milling can all be improved utilizing the superior design accuracy of Coperion K-Tron feeders.



Coperion K-Tron feeders in a snack food process

Feeder Models

Smart Weigh Belt Feeders

The Smart Weigh Belt Feeder is ideal for handling free-flowing or friable materials, particularly in large quantities. It is available with or without housing, in two sizes: 300 and 600 mm belt width.

Feed Rates:

10 dm³/hr (0.35 ft³/hr) to 80000 dm³/hr (2800 ft³/hr)

With the S60/T35 Quick Change feeder, changing from single screw feeder to twin screw feeder is a snap



Single Screw Feeders

Single screw feeders are ideal for handling free-flowing granular materials. Coperion K-Tron offers the KS60, S60 and S100 in either volumetric or gravimetric configurations.

Feed Rates:

0.4 dm³/hr (0.014 ft³/hr) to 15800 dm³/hr (560 ft³/hr)

Twin Screw Feeders

Twin screw feeders are ideal for handling difficult materials such as powders. Coperion K-Tron offers the KT20, KT35, T35 and T60 in either volumetric or gravimetric configurations.

Feed Rates:

0.12 dm³/hr (0.004 ft³/hr) to 7200 dm³/hr (250 ft³/hr)

Microfeeder

The Microfeeder is specially designed for feeding free-flowing to difficult powders (e.g. lumpy, moist or bridge-building materials) at extremely low rates with extremely high accuracy and minimal residual material left in the feeder.

Feed rates:

0.015 dm³/hr (0.0005 ft³/hr) to 27.3 dm³/hr (0.96 ft³/hr)

Liquid Loss-in-Weight Feeders

Coperion K-Tron's liquid loss-in-weight feeders provide accurate continuous volumetric or gravimetric flow control of liquids. Feed rates are dependent upon the configuration.

Dismantling the Smart Weigh Belt Feeder in Five Easy Steps



Typical Feeder Applications

- > Continuous and batch feeding of major, minor and micro ingredients
- > High accuracy feeding of extrusion, mixing, coating and milling processes
- > Multiple ingredient feeding and recipe control for packaging operations
- > Contained and highly accurate feeding of probiotics and trace elements
- > Sanitary feeding of high value inclusions for ice cream manufacture
- > Multiple ingredient batch weighing by both loss-in-weight and gain-in-weight methods
- > Metering and totalizing of ingredient usage into a variety of processes to establish true end product costs
- > Feeding of liquid flavors and additives



Coperion K-Tron feeders in a pet food coating process



Feeding Principles

Volumetric Feeding Principle

The bulk material is discharged from a hopper with a constant volume per unit of time by regulating the speed of the feeding device. The actual volume of material fed is determined through calibration. The feeding accuracy is dependent on the uniformity of the material flow characteristics and the bulk density.

Loss-in-Weight (LIW) Gravimetric Feeding Principle

The bulk material or liquid is discharged from a hopper with a constant weight per unit of time by weighing the hopper with material and regulating the speed of the feeding device depending on the actual rate of weight loss. The weighing control system compensates for non-uniform material flow characteristics and variations in bulk density; therefore providing a high degree of feeding accuracy.

When the hopper reaches a predetermined minimum weight level, the hopper is automatically refilled. During the refill period, the controller regulates the speed of the feeding device based upon the historic weight and speed information that was accumulated during the previous weight loss cycle. The LIW feeding principle is most accurate when using a high resolution, fast responding, vibration immune weighing system such as the Coperion K-Tron SFT combined with the self-tuning, compact Coperion K-Tron Control Module (KCM).

Smart Weigh Belt (SWB) Principle

The Coperion K-Tron SWB is used for continuous controlled gravimetric feeding of bulk materials. Here the controller compares the desired mass flow with the actual mass flow (weight of the material on belt x belt speed) and adjusts the belt speed accordingly. The SWB also offers an optional secondary weighbridge for continuous online auto tare, reducing maintenance, frequency of calibration, and improving long term stability.

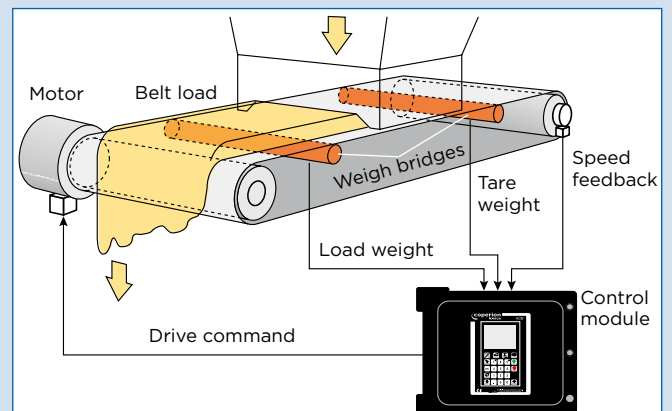

SWB Principle of Operation

Innovative Conveying Solutions

Vacuum Sequencing

Coperion K-Tron loaders and receivers are used for conveying a wide variety of bulk materials in the food and pet food industries – from granular free-flowing products to difficult flowing powders.



P-Series

The P-Series line provides a custom sanitary design for difficult conveying applications in the food industry. Design features include steep cone angles to ensure excellent discharge, easy clean design for quick assembly, cleaning and maintenance without tools, options for complete wash in place retractable spray balls, and swing out filter heads for easy filter removal. A variety of filter media is available depending on material characteristics, and all are equipped with automatic reverse jet pulsing for thorough cleaning. Capacities range from 600 to 4000 kg/hr (1320 to 8800 lb/hr).

Series 2400

The Series 2400 line offers filtered vacuum loaders and receivers for conveying a wide variety of food materials. Various models are available in painted carbon steel, stainless steel and aluminum. All models feature quick disconnect clamps for easy cleaning and filter maintenance. Capacities range from 408 to 3175 kg/hr (900 to 7000 lb/hr).



Continuous Pneumatic Conveying

Coperion K-Tron specializes in continuous pressure and vacuum conveying systems for a wide variety of food and pet food bulk applications for line sizes of 1.5 in (38 mm) up to 16 in (406 mm) and conveying capacities up to 100,000 kg/hr (220,000 lb/hr). Custom system PLC control systems can be provided to perform a wide variety of advanced functions including recipe control and bar codes/tracking.



Custom PLC controls



Stainless steel modular bin vents

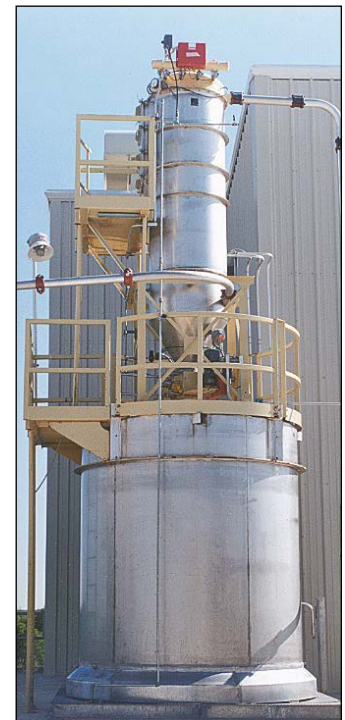

Stainless steel filter receiver

Typical Conveying Applications

- > Bulk bag, railcar and silo unloading of major ingredients such as flour, salts, corn meal, sugar, gluten, etc
- > Dense phase conveying of preblend materials to extruder or other processes
- > Refill of loss-in-weight and volumetric feeders for continuous processes
- > Gentle conveying, dense or dilute phase, for fragile materials such as popcorn, pasta, tablets and candies
- > Multi material conveying and batch weighing
- > Combined volumetric feeding and pneumatic conveying for space limitations



Combined feeder-receiver unit



Series 2400 receiver conveying salt



Multi ingredient silo unloading

Vacuum Conveying: Dense or Dilute Phase?

The difference between dilute phase and dense phase conveying lies in the air velocity and pressure differential within the conveying line.

In dilute phase conveying a large amount of air (or gas) is used to convey a small amount of material at a high velocity. Depending on the bulk density and particle size of the bulk material, typical air velocities in dilute phase conveying systems range from 16 to 30 m/s (3150 - 5900 ft/min). Since the material is literally suspended in the air during conveying, the amount of material that can be transported in this manner is limited. Generally the material to air ratio in dilute phase applications is no more than 10:1 by weight. Dilute phase systems are very simple to build, robust and reliable — even when bulk materials or material characteristics change.

In dense phase conveying a small amount of air (or gas) is used to convey a larger amount of material at low velocity. Here the pressure differential in the line causes the material to move through the line in slugs. In dense phase conveying typical air velocities range from 6 to 8 m/s (1180 - 1580 ft/min) and the material to air ratio is generally 30-50:1 by weight. Dense phase vacuum conveying is only possible in a relatively small range of applications but the low velocity means less chance of damage or segregation in the bulk material. Dense phase vacuum conveying works particularly well for fluidizable powders for conveying distances of up to 20 m (66 ft).

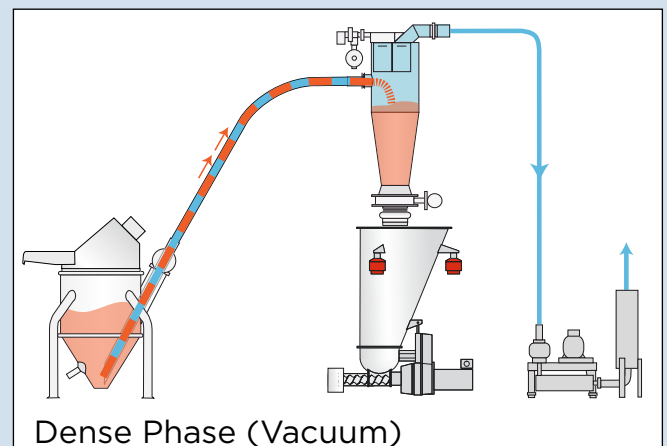
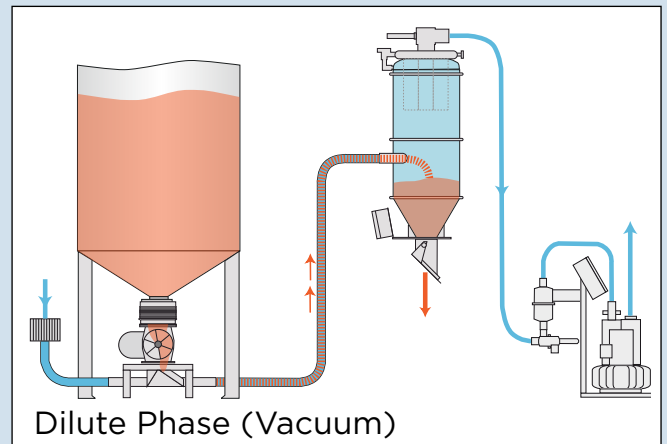

Innovative Material Handling Solutions

Bag Dump Stations and Fluidizing Feed Bins

A variety of product pick up devices are available including full sanitary stainless steel designs with capability of being washed or cleaned in place. Coperion K-Tron's innovative fluidizing cone utilizes an FDA approved perforated liner which allows the fluidization of the product via air to enhance product flow.



Batch Weighing Options

Coperion K-Tron offers a variety of systems for batch weighing of pneumatically conveyed food ingredients, whether the application requires a single ingredient to be delivered to multiple destinations or multiple ingredients to be delivered to a single destination. All systems feature one or more receiver hoppers suspended on three load cells, with an accuracy of $\pm 0.5\%$ of full scale capacity. Controls can include recipe, formula and inventory capabilities.



The Batch Weigh Vacuum Receiver combines a sanitary easy clean stainless steel vacuum receiver with a reliable weighing and control system.



The Scale Hopper uses three load cells supporting a mild steel painted, aluminum or stainless steel hopper.

Aerolocks

Coperion K-Tron AeroLock™ rotary valves are backed by more than 50 years of application experience. With five models in over 150 sizes and configurations, Coperion K-Tron has the right AeroLock for every application.

The Quick-Clean AeroLock is particularly well suited for use in the food industry where contamination is a constant concern and frequent disassembly and cleaning is required. The Quick-Clean AeroLock can be easily disassembled, cleaned, and reassembled without disengaging it from the system.

Heavy-Duty (HD) - for heavy-duty industrial service and high-volumetric efficiency

Maximum-Duty (MD) - for heavy to severe industrial service

Quick-Clean (QC) - for frequent disassembly and cleaning requirements

Blow-Through (BT) - enhances rotor cleanouts and for tight installations

Light-Duty (LD) - for low pressure or low vacuum service



Blow-Through AeroLock

Gain-in-Weight vs Loss-in-Weight Batching Principles

Flow Aid Devices

For ingredients with difficult flow characteristics, there are a variety of innovative options available to enhance product flow and overall efficiency of a process.

Aeration Pads

Low profile aeration pads provide an effective flow aid for bins or hoppers by simultaneously aerating and vibrating the bulk material inside the vessel.



Fluidization Beds

Designs are available using FDA approved liners for smaller hoppers or large diameter tanks/silos. This device introduces low pressure air into the material to fluidize the product and assist flow.



ActiFlow

The Coperion K-Tron ActiFlow is a non product contact device which reliably prevents bridge building of cohesive materials, eliminating the need for vertical agitation in loss-in-weight feeders.



ActiFlow is mounted outside the product zone and has minimal space requirements



Gain-in-weight batch feeding system

Gain-in-Weight (GIW) Batching Principle

In GIW batching volumetric metering devices sequentially feed multiple ingredients into a collection hopper mounted on load cells. Each feeder delivers approximately 90% of the ingredient weight at high speed, slowing down towards the end of the cycle to deliver the last 10% at a reduced rate to ensure higher accuracy. The GIW controller monitors the weight of each ingredient and signals each volumetric feeder to start, increase or reduce speed, or stop accordingly. Once all ingredients have been delivered, the batch is complete and the mixture is discharged into the process below.

Loss-in-Weight (LIW) Batching Principle

LIW batching is used when the accuracy of individual ingredient weights in the completed batch is critical or when batch cycle times need to be very short. Gravimetric feeders operating in batch mode simultaneously feed multiple ingredients into a collection hopper. Adjustment of the delivery speed (on/off, fast/slow) lies with the LIW feeder controls and the smaller weighing systems deliver highly accurate batches for each ingredient. Once all ingredients have been delivered, the batch is complete and the mixture is discharged into the process below. Since all ingredients start and stop their batches approximately at the same time, the overall batch time as well as further mixing times downstream are greatly reduced.

LIW and GIW

In some cases where small amounts of micro ingredients are required for a large overall total batch, both methods are employed: LIW feeders for the micros and minors, and GIW batchers for the major ingredients.

A Wide Range of Solutions

Coperion K-Tron has extensive experience in providing conveying, feeding and material handling equipment for a wide variety of food and pet food processes. Listed below are just a few examples of systems provided in the past.

Dense Phase Conveying and Feeding of Pre-Blends to an Extruder

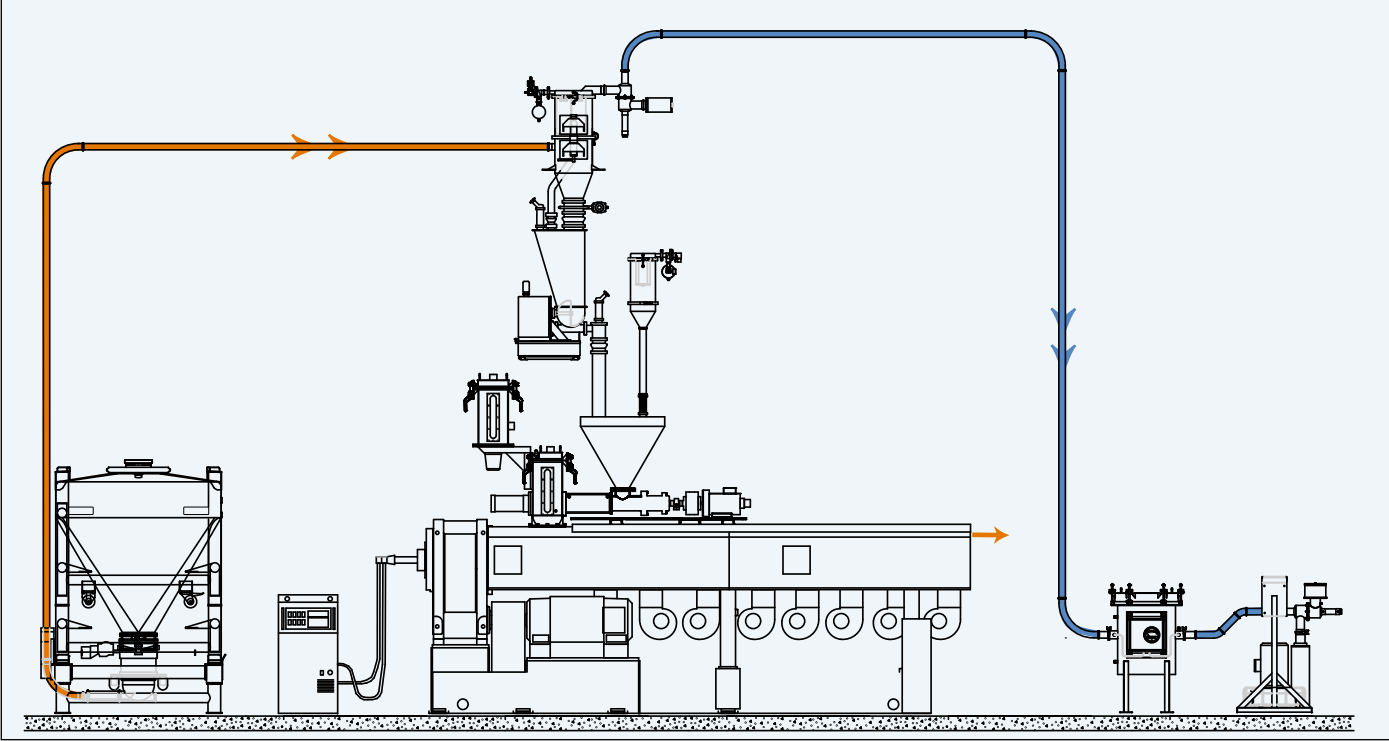

Batch Weighing of Multiple Ingredients

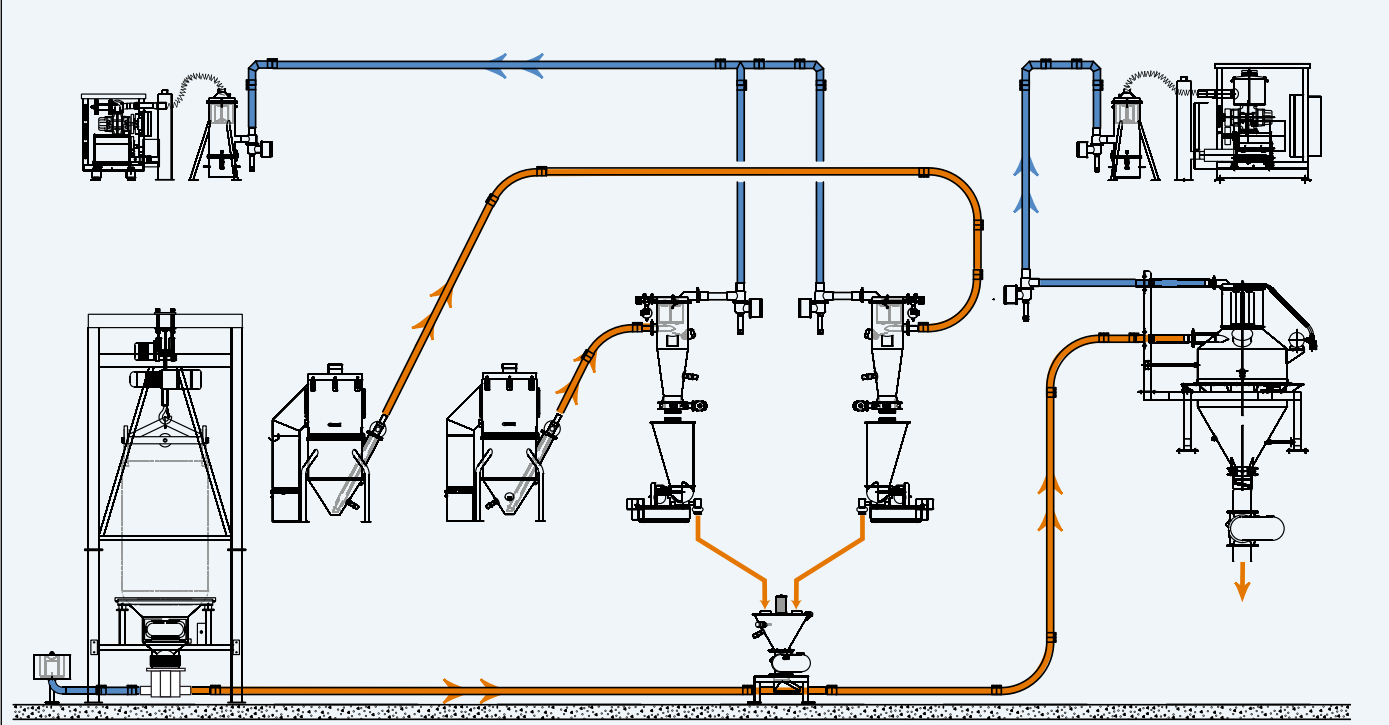

Conveying and Feeding in a Continuous Mixing Process

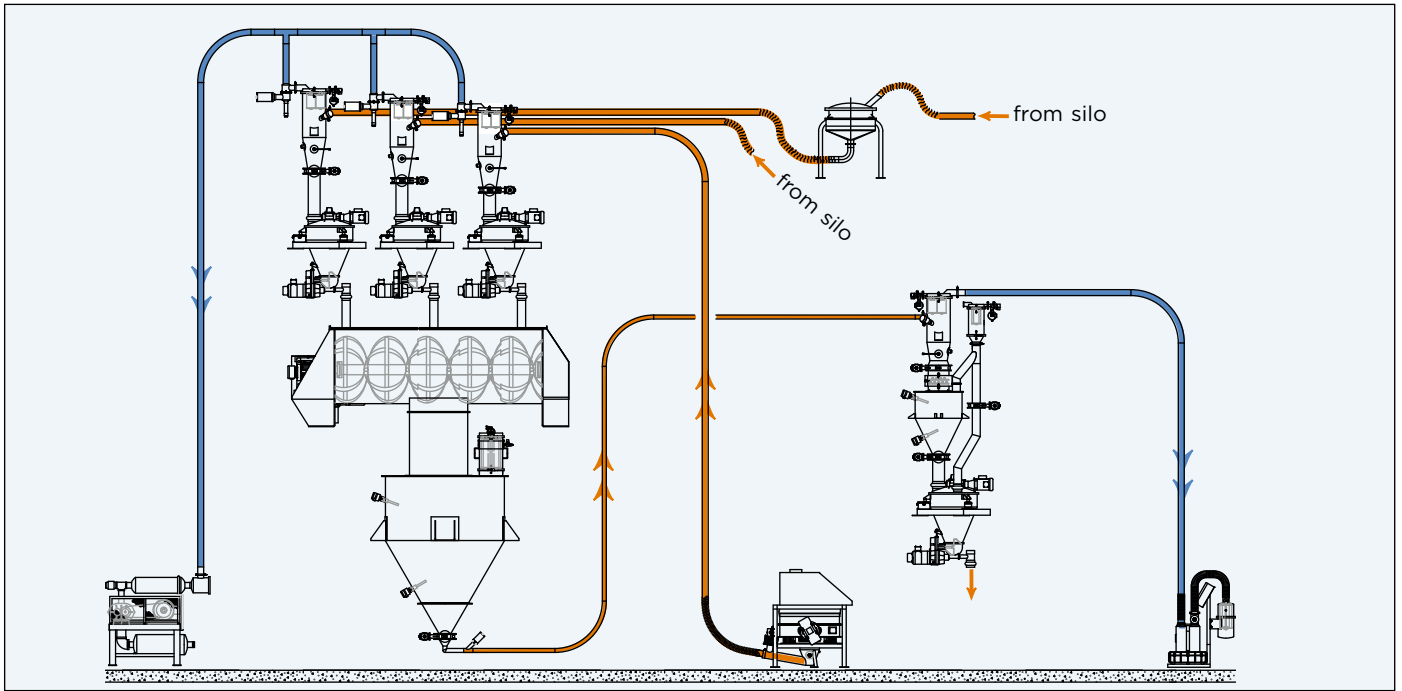

Multi Ingredient Dispensing via Smart Weigh Belt Feeders

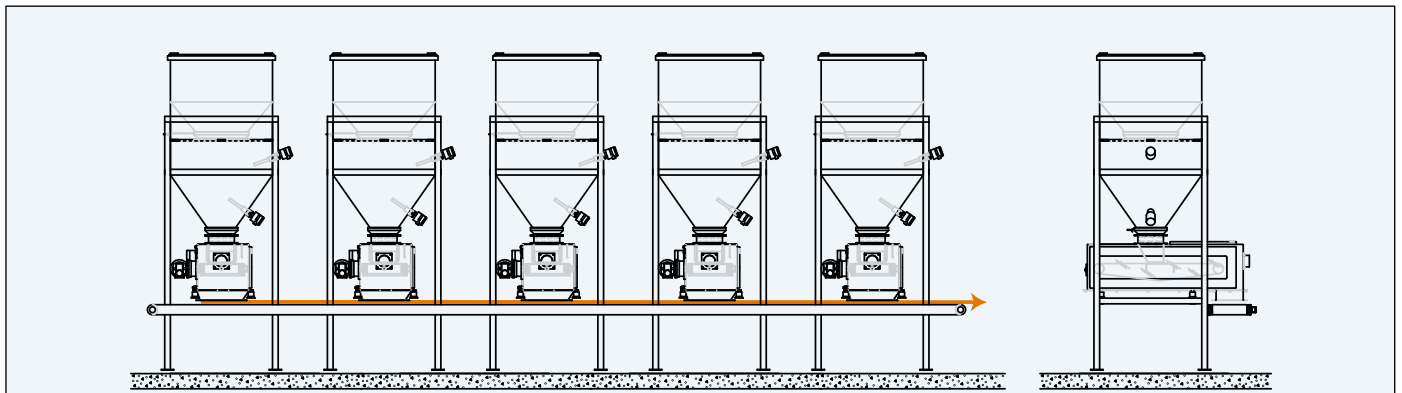

Scaling System for Multi Destination Batching

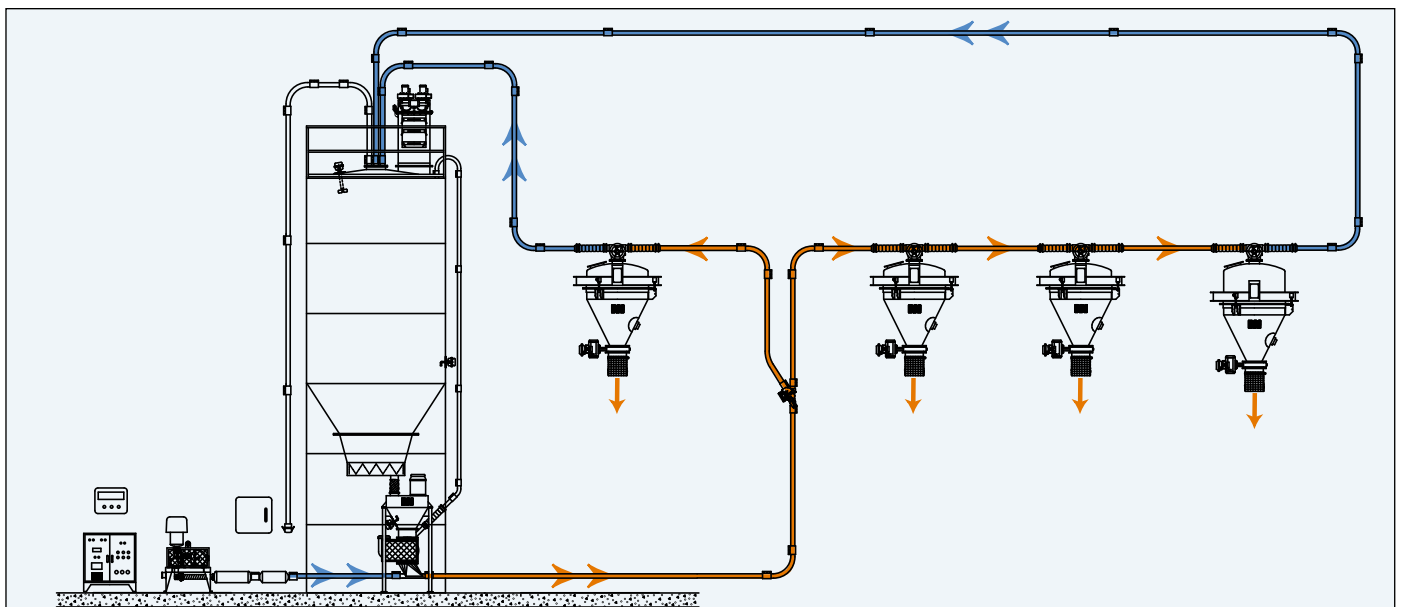

Smart Solutions for Material Handling

Since its creation in 1964, K-Tron has defined the leading edge of technology for material handling applications in the process industries. K-Tron designs, produces, sells and supports feeding and conveying equipment as well as complete process solutions.

Coperion K-Tron Test Labs

Fully equipped testing facilities help in making the optimal equipment selection.

Systems Engineering Support

One source engineering of your entire material handling project. Our system engineer will work with you from concept to commissioning.

Worldwide Service Support

Trained, certified service engineers located around the world to provide twenty-four hour technical support and solve your problem any time, any day.

Custom Service Programs

Start-up and preventive maintenance programs designed for your specific installation.

Spare Parts

Quick delivery so you can safely limit your inventory to the most critical parts.

Professional Training

The Coperion K-Tron Institute provides hands-on maintenance, mechanical and operator training for all of your Coperion K-Tron equipment, either on-site or at a Coperion K-Tron facility.



www.coperionktron.com

>Manufacturing, Sales and Engineering:

Coperion K-Tron Pitman, Inc.
590 Woodbury-Glassboro Rd
Sewell, NJ 08080 USA
Tel +1 856 589 0500
Fax +1 856 589 8113
E-mail: info@coperionktron.com

Coperion K-Tron Salina, Inc.
606 North Front St.
Salina, KS 67401 USA
Tel +1 785 825 1611
Fax +1 785 825 8759
E-mail: info@coperionktron.com

Coperion K-Tron (Switzerland) LLC
Lenzhardweg 43/45
CH-5702 Niederlenz
Tel +41 62 885 71 71
Fax +41 62 885 71 80
E-mail: ks@coperionktron.com

>Sales and Engineering:

Asia Pacific
Coperion K-Tron Asia Pte Ltd
21 Bukit Batok Crescent
#22-79 Wcega Tower
Singapore 658065
Tel +65 6899 7255
Fax +65 6569 7600
E-mail: kap@coperionktron.com

British Isles
Coperion K-Tron Great Britain Ltd.
4 Acorn Business Park
Heaton Lane
Stockport SK4 1AS
United Kingdom
Tel +44 161 209 4810
Fax +44 161 474 0292
E-mail: kb@coperionktron.com

China
Coperion K-Tron (Shanghai) Co. Ltd.
Building A2- A3
No. 6000 Shen Zhuan Gong Road
Songjiang district
CN-201619 Shanghai
Tel +86 21 6375 7925
Fax +86 21 6375 7930
E-mail: kcn@coperionktron.com

France
Coperion K-Tron France S.à.r.l.
56, boulevard de Courcerin
FR-77183 Croissy-Beaubourg
Tel +33 1 64 80 16 00
Fax +33 1 64 80 15 99
E-mail: kf@coperionktron.com

Germany
Coperion K-Tron Deutschland GmbH
Im Steinigen Graben 10
DE-63571 Gelnhausen
Tel +49 6051 9626 0
Fax +49 6051 9626 44
E-mail: kd@coperionktron.com



coperion
K-TRON