



Coperion Polyolefin Compounding Equipment. Superior Solutions for Material Handling, Feeding, Extrusion, and Pelletizing.

»» Reliable Coperion solutions. For highest throughput rates in polyolefin production.

Coperion has a long history as a proven partner for the design and realization of complete polyolefin production plants. As market and technology leader, we have a unique wealth of know-how for all process stages along the polyolefin production chain – from material handling, powder and pellet mixing to feeding, extrusion and devolatilization through pelletizing and storage. All key components are proprietary developments and are produced at one of our many production sites.

Our innovative technologies are the proven result of decades of continuous research and development work. We ensure the perfect alignment of all process steps, maximizing economy for the required throughput rates and providing the highest product quality.

Our scope of equipment and systems includes a wide range of technological solutions for annual production of up to 1000 kta of polyolefins.

PRODUCTION CAPACITIES

PP	Throughput rates up to approx. 100 t/h
LLDPE	Throughput rates up to approx. 125 t/h
HDPE	Throughput rates up to approx. 135 t/h
LDPE	Throughput rates up to approx. 80 t/h

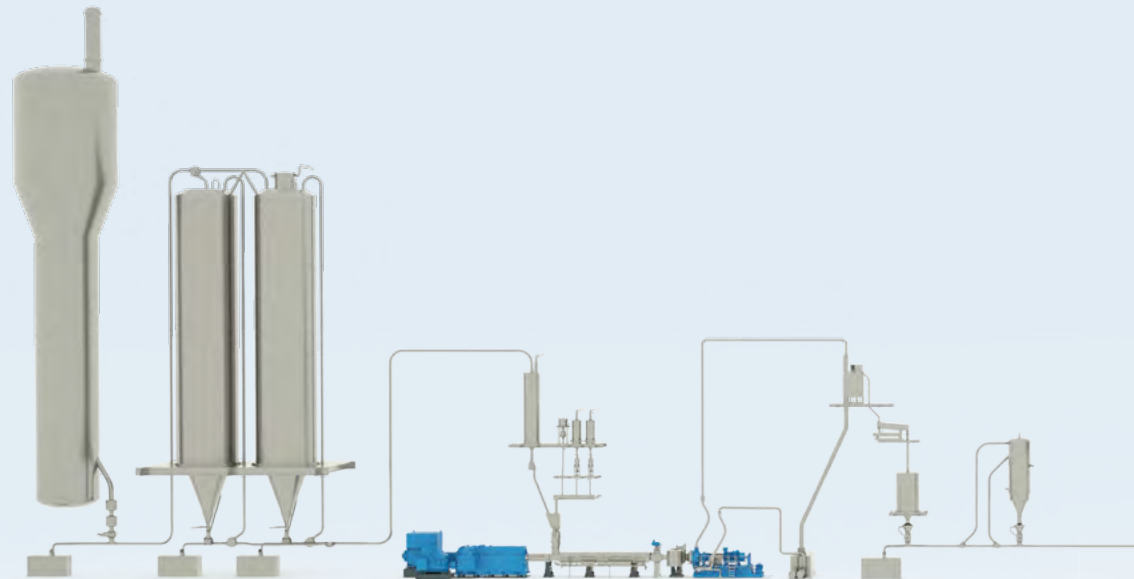

BULK MATERIAL HANDLING

Pneumatic and hydraulic conveying processes together with all associated steps, such as cooling, heating, volatile organic compound discharge (VOC degassing), blending, separating and cleaning

FEEDING

Wide range of solutions for resin and additive feeding, such as Smart Flow Meters K-SFM and loss-in-weight feeders for solids and liquids

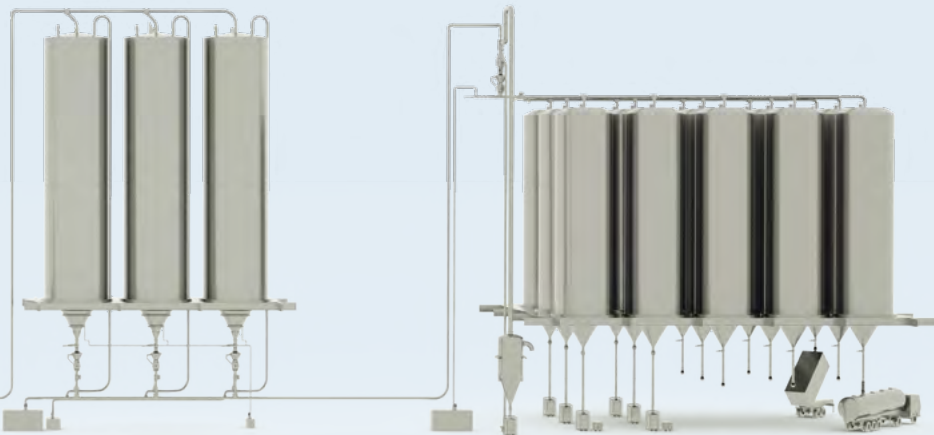
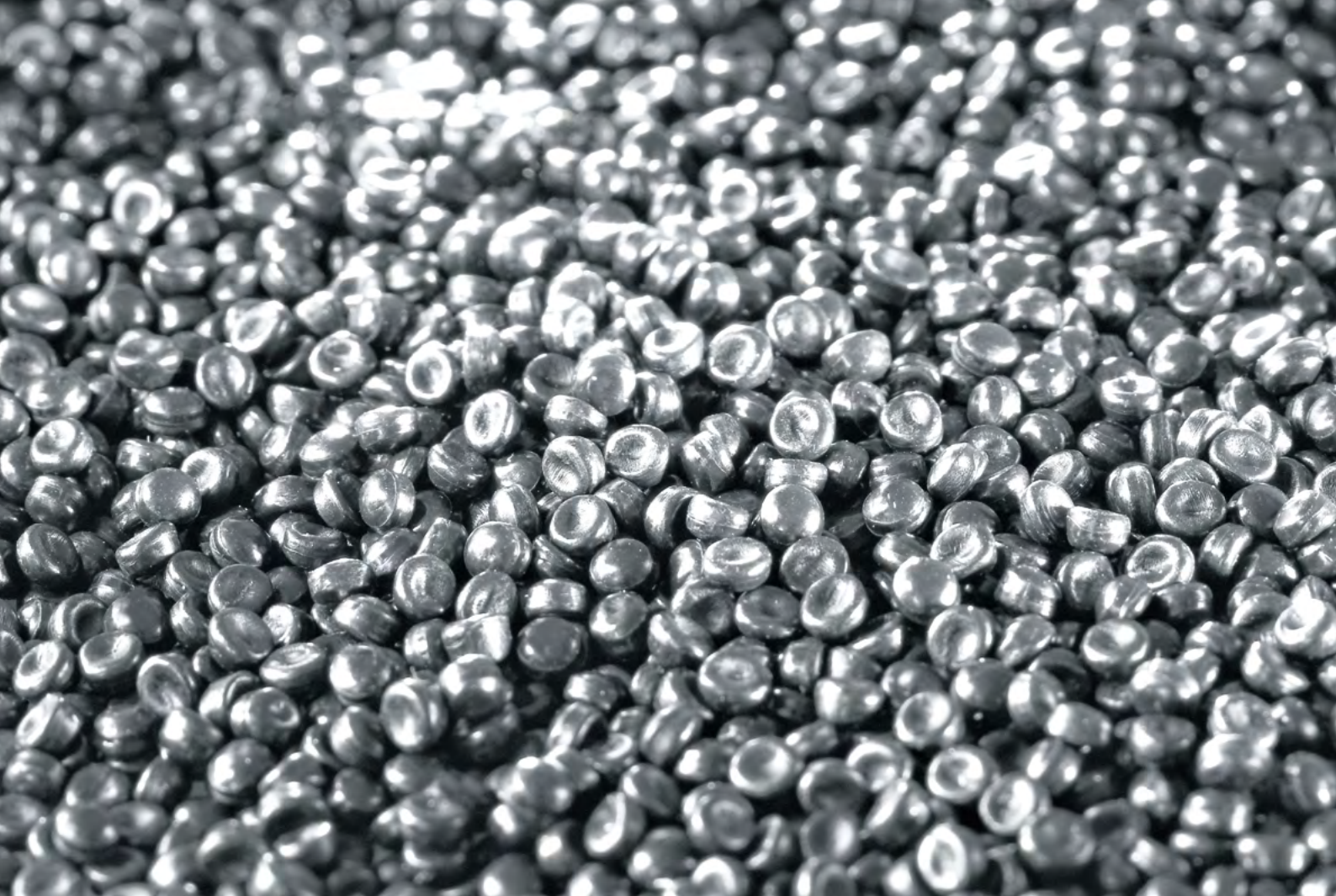

ZSK TWIN SCREW EXTRUDER

Superior equipment at the highest technical level which reliably transfers all ingredients into a homogeneous melt

PELLETIZERS

First-class equipment to process the melt into high-quality, uniform pellets - at maximum throughput rates and with the greatest possible cost-effectiveness

PLANT DESIGN

We have unique know-how for all process stages and develop and manufacture all key components required for the overall process. Our solutions suit customer requirements by means of first-class project management and engineering.

DISPATCH MANAGEMENT AND REPORTING

Railcar, container, truck and forklift yard traffic management including mobile and stationary peripherals

Processes.

COMPOUNDING AND PELLETIZING OF POLYOLEFINS

In powder-fed polyolefin processes silos are used for storage or mixing of the powders. Upon discharge from the silos, the powders are transferred to the production area, where they are fed into the ZSK extruder via a Coperion K-Tron Smart Flow Meter K-SFM in combination with a rotary valve. Additives and additional polymers are added to the mixture via Coperion

K-Tron loss-in-weight feeders. Depending on the process task, all ingredients are intensively mixed, homogenized, and devolatilized within the ZSK extruder, before the melt is pelletized in Coperion's UG underwater pelletizer. The pellets are then dried, screened, stored, mixed and packaged in bags/containers or delivered to railcars.

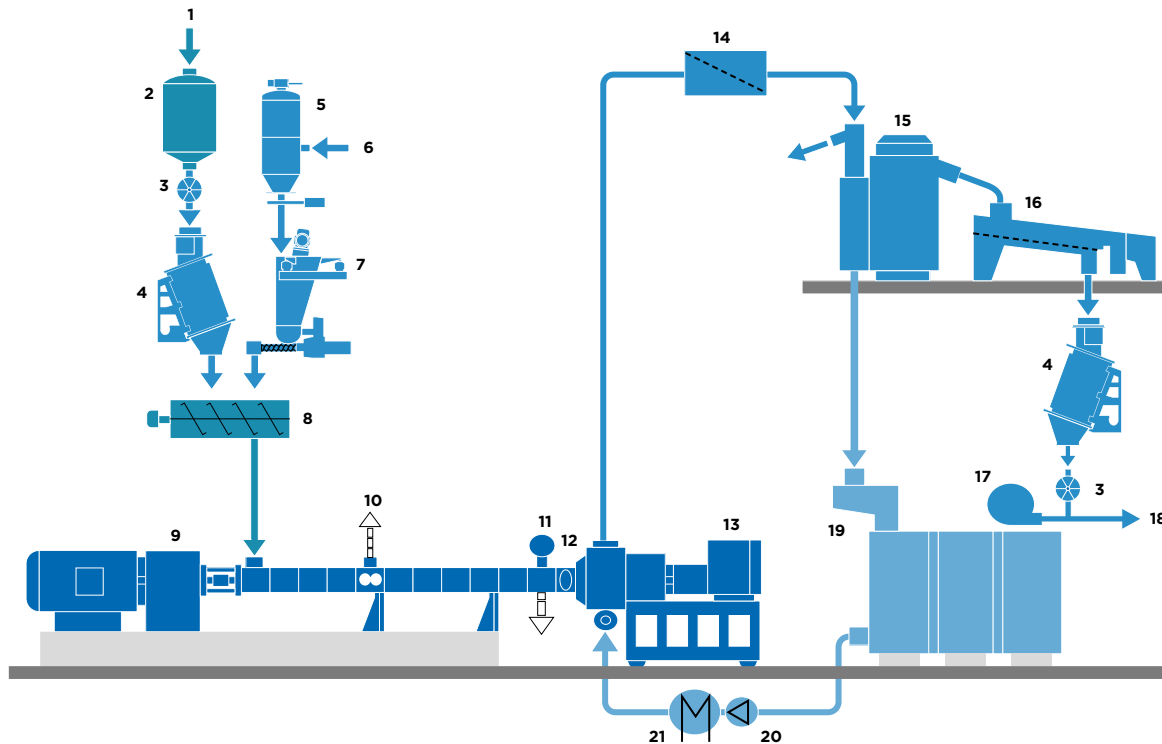

- | | | | |
|-----------------------------|--|--|--|
| 1 HDPE, LLDPE or PP | 7 Loss-in-weight feeder | 12 SWZ screen pack changer | 17 Fan/blower |
| 2 Buffer hopper | 8 Continuous mixing and conveying screw (optional) | 13 UG underwater pelletizer | 18 To storage (silo, bagging, railcar loading) |
| 3 Rotary valve | 9 ZSK twin screw extruder | 14 Pellet water start-up screen (optional) | 19 Pellet water tank |
| 4 Smart Flow Meter (K-SFM) | 10 ZS-EG side devolatilization unit (optional) | 15 Pellet dryer | 20 Pump |
| 5 Vacuum receiver | 11 Throttle start-up valve | 16 Classifying screen | 21 Heat exchanger |
| 6 Additives/additive premix | | | |

POLYMERS

HDPE, LLDPE, PP

THROUGHPUT

135 t/h

TECHNOLOGY BENEFITS

- › A wide range of specialized conveying and material handling solutions ensures bulk materials are always in the right place at the right time
- › Accurate and reliable feeding equipment improve product quality and reduce waste
- › ZSK extruder features good intake and conveying properties
- › Gentle and stable melting of the powder within the ZSK (even at reduced throughput rates)
- › Narrow residence time distribution leads to consistent polymer treatment and quality
- › Perfect homogenization of additives in the polymer melt
- › Effective pressure build-up with low energy input
- › Modular design of Coperion technology allows individual adjustments, even after commissioning

DISCHARGE OF LDPE/EVA FROM LPS

The ZSK extruder is designed with a large feed opening to ensure proper intake of the melt from the LPS, allowing the LPS to operate at low pressure and reducing equilibrium residual volatile levels. The ZSK self-cleaning screw profile provides excellent mixing capabilities for additive incorporation without buildup

on the screw flights. A lateral extruder generates the additive batch and pressurizes this into the main ZSK extruder. Screening follows, if required, via a screen pack changer. Pelletizing is performed by an underwater pelletizer, capable of pelletizing both high and low viscosity melts into homogeneous pellets.

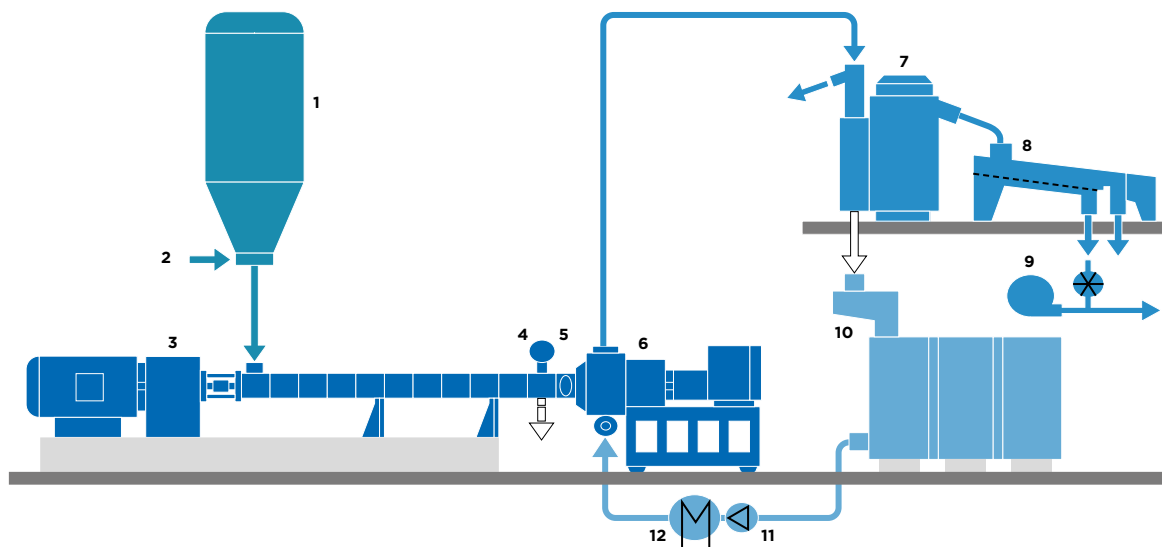

1 LPS low pressure separator
2 Melt gate
3 ZSK twin screw extruder

4 Throttle start-up valve
5 SWZ screen pack charger
6 UG underwater pelletizer

7 Pellet dryer
8 Classifying screen
9 Fan/blower with rotary valve

10 Pellet water tank
11 Pump
12 Heat exchanger

POLYMERS
LDPE/EVA

THROUGHPUT
80 t/h

TECHNOLOGY BENEFITS

- › Long proven solutions
- › Closely intermeshing twin screws of the ZSK with tight, self-wiping profile
- › Self-cleaning equipment, no fouling, no downtime required for cleaning
- › Homogeneous incorporation of additives (dispersion)
- › Best degassing performance
- › Reliable pelletizing and pellet treatment system

Processes.

DEVOLATILIZATION OF POLYMER AND RUBBER SOLUTIONS

POE/POP or other devolatilization processing can be realized in two different ways. If no degassing is required, a small ZSK is sufficient to generate the additive batch and to pressurize it for the main polymer stream. Screening and pelletizing is performed by a Coperion underwater pelletizer, able to pelletize melts with a wide range of viscosities and high stickiness into

homogenous pellets. Removing high solvent contents from the polymer melt requires a setup with multiple degassing zones. High melt temperatures and multiple surface area replacements make the ZSK twin screw extruder the ideal degassing system for this challenge.

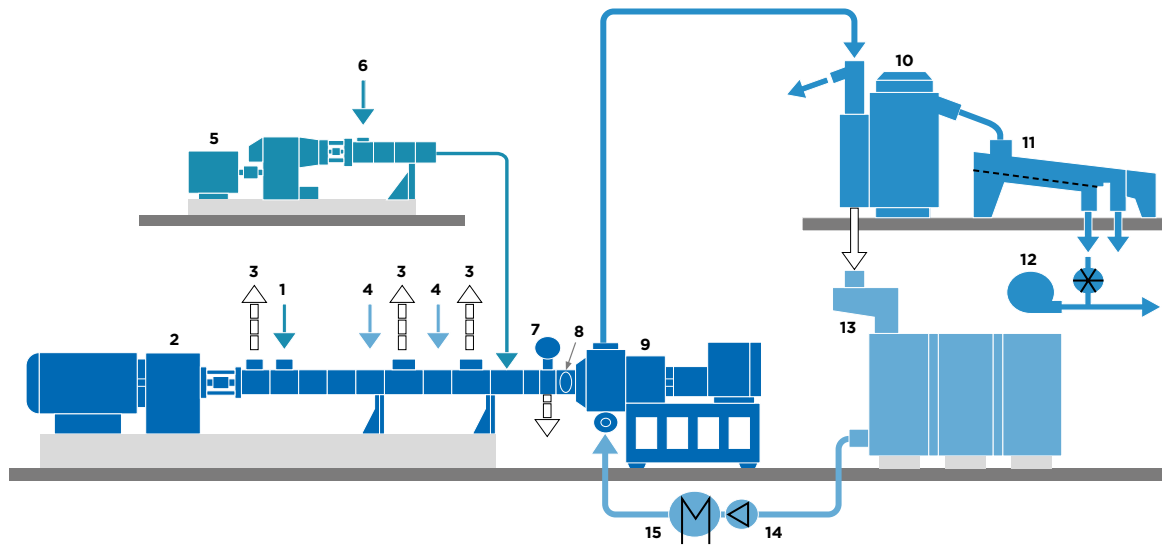

- | | | | |
|---------------------------|---------------------------|---------------------------------|----------------------|
| 1 Product feeding | 5 ZSK twin screw extruder | 9 UG underwater pelletizer | 13 Pellet water tank |
| 2 ZSK twin screw extruder | 6 Feeding of additive mix | 10 Pellet dryer | 14 Pump |
| 3 Degassing | 7 Throttle start-up valve | 11 Classifying screen | 15 Heat exchanger |
| 4 Stripping medium | 8 SWZ screen pack changer | 12 Fan/blower with rotary valve | |

POLYMERS

Polyolefin Elastomer (POE) or Polyolefin Plastomer (POP)

THROUGHPUT

65 t/h

TECHNOLOGY BENEFITS

- > Proven solutions
- > Self-cleaning equipment, no fouling, no downtime required for cleaning
- > Ideal incorporation of additives (dispersion)
- > Best degassing performance
- > Easy reprocessing of production waste
- > Reliable pelletizing and pellet treatment system

➤ PROCESSING OF BIMODAL POLYETHYLENE

Bimodal polyethylene requires high demands on the homogenization due to the wide molecular weight distribution. The long-chained molecules which are responsible for the strength

in the end product must be worked into the short-chained molecule matrix during compounding. This process has a decisive influence on the post processing of the product.

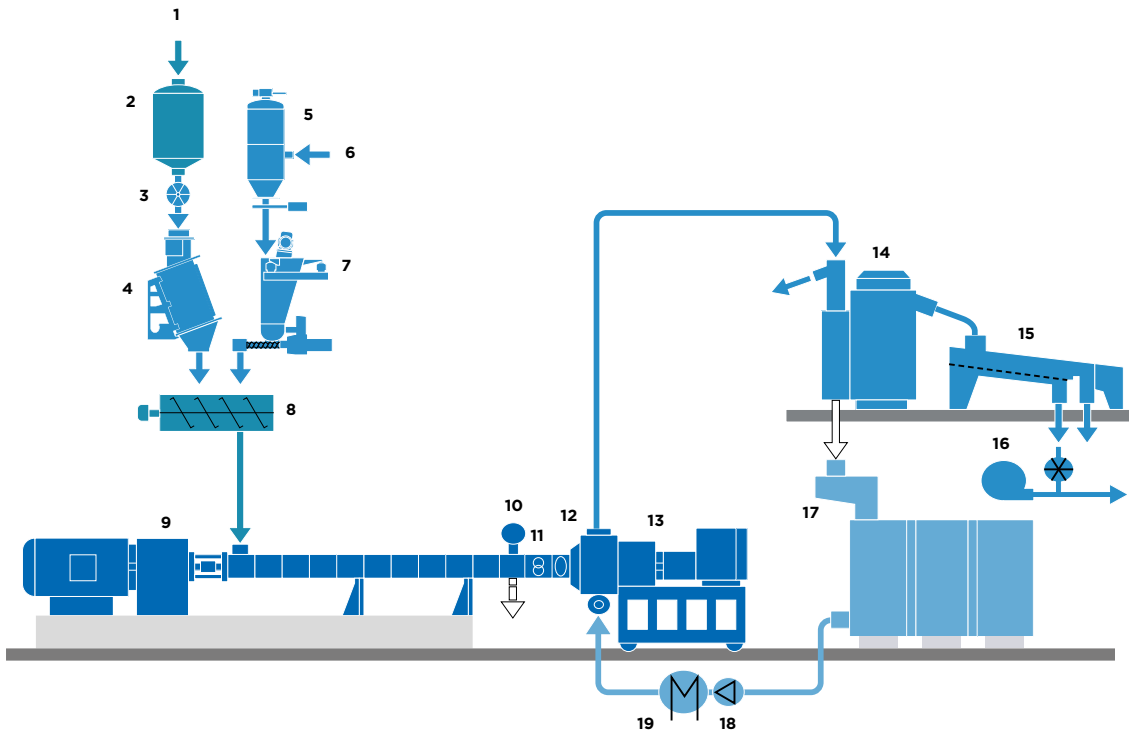

- 1 HDPE, LLDPE or PP
- 2 Buffer hopper
- 3 Rotary valve
- 4 Smart Flow Meter (K-SFM)
- 5 Vacuum receiver

- 6 Additives/additive premix
- 7 Loss-in-weight feeder
- 8 Continuous mixing and conveying screw (optional)
- 9 ZSK twin screw extruder

- 10 Throttle start-up valve
- 11 MP melt pump
- 12 SWZ screen pack changer
- 13 UG underwater pelletizer
- 14 Pellet dryer

- 15 Classifying screen
- 16 Pneumatic conveying
- 17 Pellet water tank
- 18 Pump
- 19 Heat exchanger

POLYMERS

HDPE

THROUGHPUT

94 t/h

TECHNOLOGY BENEFITS

- Licensor approved setup
- Superior product quality
- High performance equipment with extended mixing and homogenization capabilities
- Setup proven for multi-colored applications with fast changeover time (less than five hours for change from black to natural production, dependent on setup, no manual cleaning required)

» Processes.

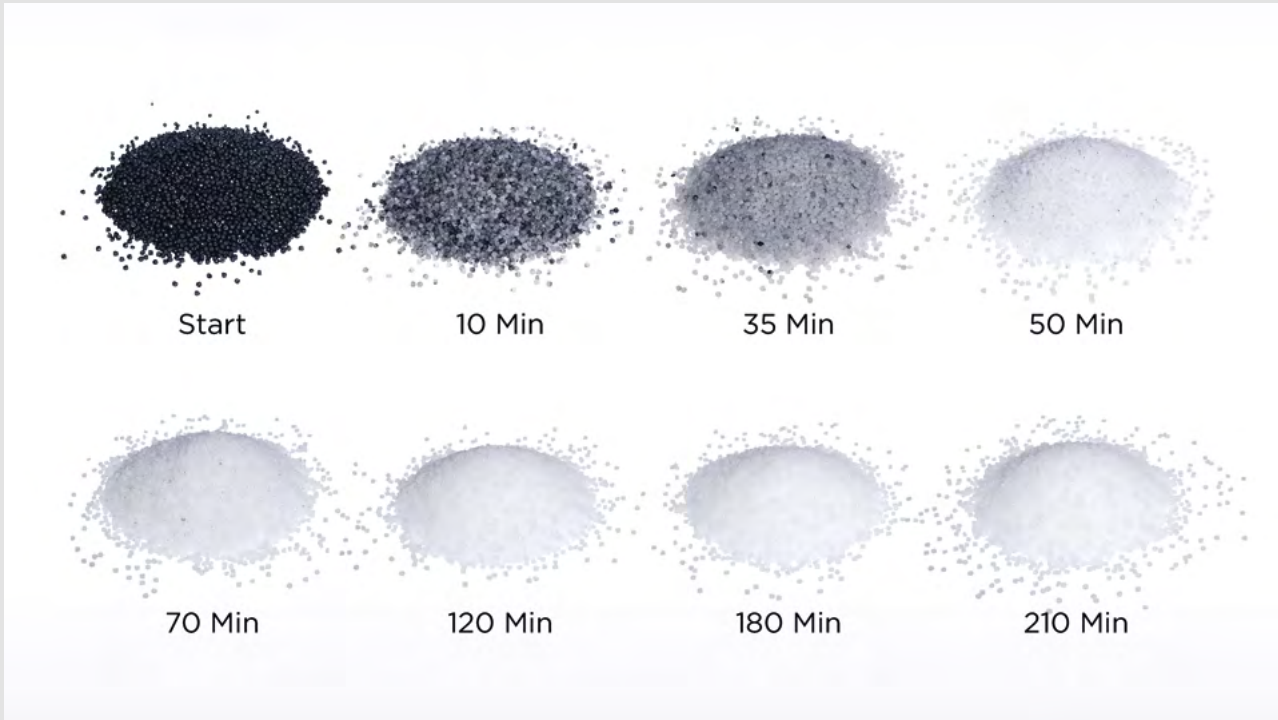

» COPERION COLOR CHANGE CONCEPT WITH THE ZSK MEGAcompounder

With Coperion's innovative concept, color changes in polyolefin production are possible from natural to black pellets as well as from black pellets to natural - without interrupting production and without completely cleaning the system. This concept works with any other color as well. Changeover time from

black to color is less than five hours. In addition, the cost for Coperion's innovative process solution is significantly lower than for conventional solutions because less equipment is needed and less space is required. The Coperion color change concept provides 100 % prime product - with zero waste.

» RECYCLING IN POLYOLEFIN PRODUCTION

Coperion systems already incorporate process setups that feed product streams of recycled plastics into the production of polyolefins. Chemicals, waxes or liquid energy carriers obtained via chemical recycling of PCR (pyrolysis process) can be fed back to the reactor as polymer feedstock to produce new plastic. PCR can be recycled mechanically, and the homogeneous melt achieved via this process can be directly fed downstream into the large-scale polyolefin production extruder parallel to the

virgin material feed. To meet very high mechanical and as well as sensory demands for the intended application, Coperion offers a variety of solutions all along the process to remove unpleasant odors from plastic. These technologies excel due to their especially reliable and energy-efficient operation. Using Coperion's mobile deodorizing unit, specific odor reduction potential can be tested at your location on freshly produced product under actual production conditions.





› ENERGY SAVINGS IN POLYOLEFIN PRODUCTION

Polyolefin production faces two key challenges: rising energy costs and the need for carbon footprint reduction. By modernizing your plant with retrofitted state-of-the-art solutions, you can reduce energy consumption, increase sustainability and cut carbon emissions.

As a key technology partner, Coperion has the overall process knowledge to engineer tailored retrofit solutions which deliver continuous improvement and a fast return on investment (ROI). Older plants offer even greater potential for process optimization and energy savings.

› DEGASSING TECHNOLOGIES

Several polyolefin production processes require degassing as one process step. Depending on the process, small (< 0.2%) to large amounts (ca. 50%) of volatiles have to be removed from the polymer melt resp. solution or the solid polymer pellet. Volatiles

could be VOC or monomers for LDPE production, peroxide for PP production, and moisture gases like air or solvents in other applications. Coperion offers manifold degassing solutions depending on the individual process requirements.

Material handling technology. Coperion supplies a wide range of tailored solutions, from components and systems up to complete plants for handling powder and pelletized bulk materials.



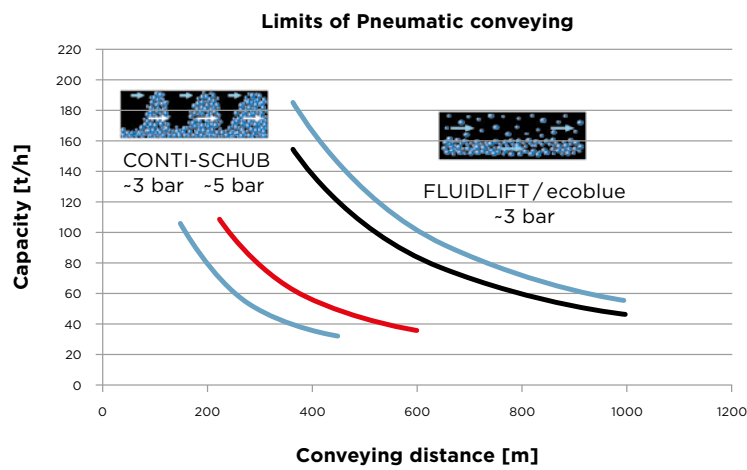

From reactor charging and discharge to additive handling in extrusion processes and logistics, Coperion provides solutions for bulk material handling for all types of plastics. Our scope of equipment and services not only includes pneumatic and

hydraulic conveying processes, but also all associated processes such as cooling, heating, discharge (VOC degassing), blending, separating and cleaning.

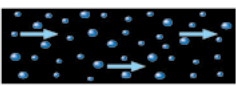
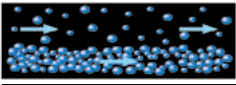

CONVEYING

When handling both powders and pellets Coperion meets the high demands for increasing production capacities and conveying distances with a wide and selectively developed range of innovative conveying processes and components.

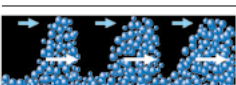
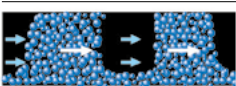
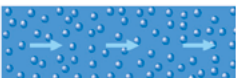
	Type of conveying	Brand name	Speed	Products
	Lean-phase conveying	FLUIDLEAN®	25-40 m/s	Powders, fluffs, pellets
	Strand conveying	FLUIDLIFT® FLUIDLIFT® ecoblue	15-30 m/s	Powders, fluffs, pellets
	Fluid-phase conveying	SUPERDENSE®	8-20 m/s	Fluidizable powders
	Stabilized fluid-phase conveying	FLUIDSTAT®	8-20 m/s	Fluidizable powders
	Stabilized slug conveying	FLUIDSPLIT®	4-10 m/s	Non-fluidizable powders, Abrasive powders
	Slug conveying	CONTI-SCHUB®	4-10 m/s	Pellets
	Slug conveying	TAKT-SCHUB®	4-10 m/s	Pellets
	Hydraulic conveying	CONTICON®	1-5 m/s	Pellets

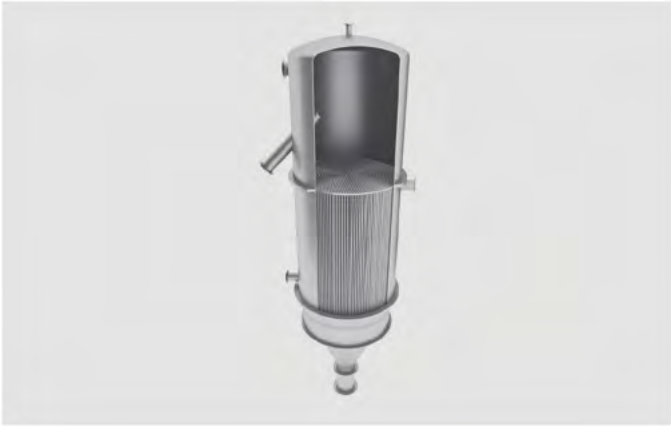

➤ **BULK-X-CHANGE® BULK MATERIALS HEAT EXCHANGER**

Thermal treatment of the product is required in many bulk solids processing systems, which means the product needs to be either heated or cooled. The Coperion Bulk-X-Change® bulk material heat exchanger is a highly-efficient, space and cost-saving device – the ideal solution for thermal treatment of the most bulk materials.



➤ **CLEANING AND SEPARATING**

The purity of bulk materials is a decisive factor for the quality of the end product. We focus on minimizing dust generation during the design process for conveying systems. Reduced conveying velocities, suitable pipe materials and connections ensure minimal attrition during production. A varied range of filters and separator concepts are employed to suit the product properties and application requirements.

➤ **BLENDING AND HOMOGENIZATION**

For static homogenization of bulk materials in silos, Coperion offers the FCB Fluid Cone Blender and the CFB Combiflow® Blender. Both units have a homogenization capacity of up to 200 t/h in 1200 m³ silos.



Powerful components for all process stages. Discharging, dosing, conveying, separating, cleaning, mixing, heating, cooling, etc.

To maintain the quality of your products at a consistently high level, powders and pellets (e.g. PP, PE, PET, PA, PVC) must be handled and conveyed optimally at each stage of the process chain in accordance with their respective properties. Comprehensive and ongoing research and development enable us to

offer you innovative concepts and components from our own manufacturing facilities for your production. You therefore profit from components that are tailored perfectly to your needs and ensure that your products are handled as reliably, economically and gently as possible.

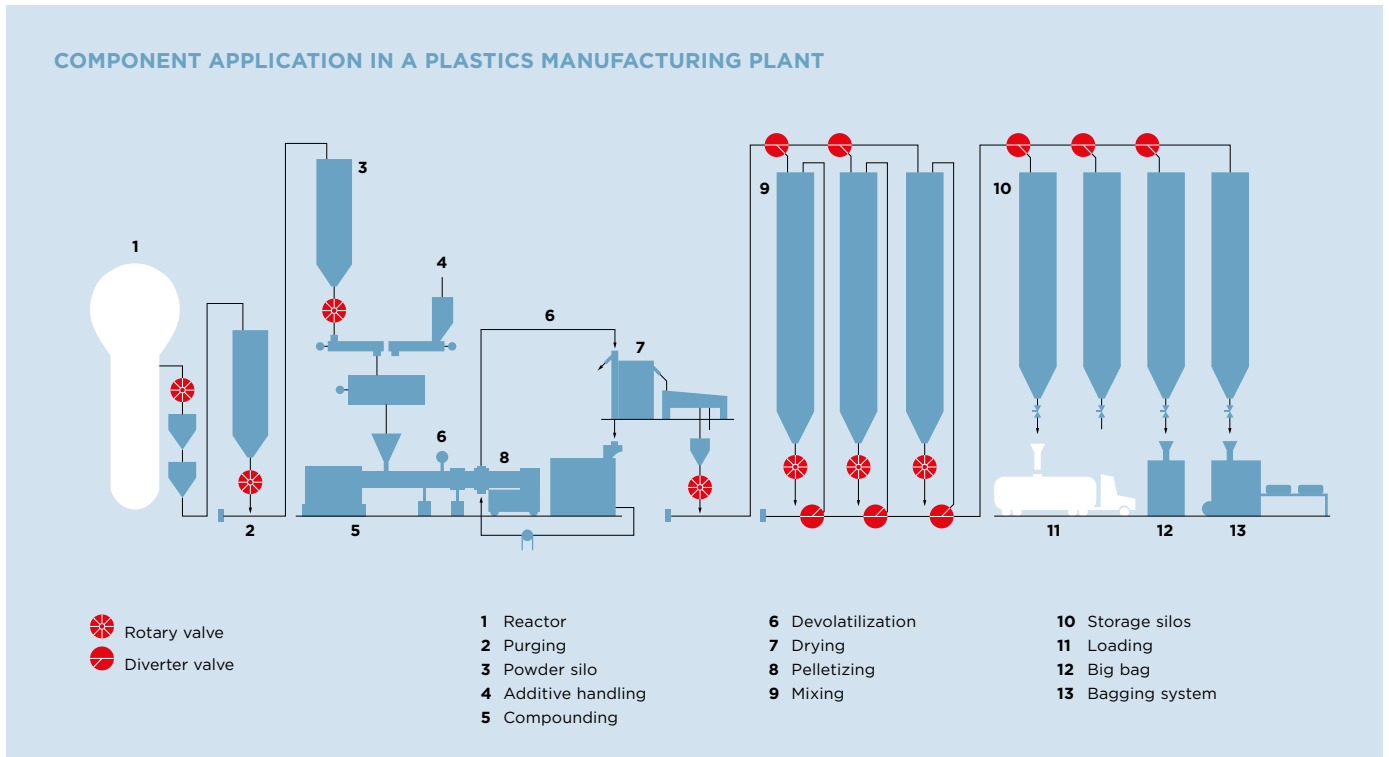

ROTARY VALVES

ROTARY VALVES FOR POWDERS

Benefits: Large inlet. Unrestricted product flow. High filling efficiency.

ROTARY VALVES FOR GRANULAR PRODUCTS

Benefits: Patented anti-chopping inlet geometry. Safe starting.

OPTIONS AND ACCESSORIES FOR ROTARY VALVES

Optimal rotary valve design for the individual application.



DIVERTER VALVES



K DESIGN

Asymmetric design with 35° to 45° angle suitable for distributing and collecting in conveying lines and gravity pipes.



T DESIGN

Rectangular design with 90° angle for silo filling.



V DESIGN

Symmetric design with 50° angle for gravity lines.

»» Feeding technology. Coperion K-Tron is the premier provider of accurate and reliable feeding equipment for the handling of both resin and additives in polyolefin production processes.



» SMART FLOW METER (K-SFM)

Coperion K-Tron's Smart Flow Meter (K-SFM) product line provides a reliable and highly accurate means for measuring production rate and adjusting additive feeder setpoints in real time. The K-SFM can be employed in powder/fluff service to measure the rate of base resin into the extruder, or it can be employed in the pellet stream after the classifier to measure total line output. With no moving parts in the product contact areas and an online auto-tare and bypass system, the K-SFM is designed for reliable operation at production rates up to 350 m³/h.

» LOSS-IN-WEIGHT (LIW) FEEDERS

Coperion K-Tron offers a complete range of single and twin screw loss-in-weight feeder configurations for the handling of additives in any form: pellets, premixes/dust-free blends, or powders. We have decades of experience with handling additives with poor flow characteristics at high accuracies. In addition to handling bulk solid additives, Coperion K-Tron offers a line of liquid feeders well-suited for the handling of liquid additives, such as peroxide.

➤ Extrusion technology.

The ZSK MEGAcoumponder is a closely intermeshing, co-rotating twin screw extruder, providing highest throughput rates and productivity. The modular design of the process section allows various zones to be configured as required for conveying, plasticizing, mixing and shearing, homogenizing, devolatilizing and pressure build-up. The ZSK achieves maximum throughput rates and first-class compound qualities with outstanding process reliability.

- Good intake and conveying properties
- Gentle and stable melting of the powder
- Good homogenization of additives in the polymer melt
- Effective pressure build-up with low energy input

ZSK MEGAcoumponder	Specific torque Md/a^3 [Nm/cm ³]	Max. screw speed [min ⁻¹]	Max. drive power N [kW]
177 Mc	12.5	550	4500
250 Mc	12.5	500	11200
320 Mc	12.5	400	18600
350 Mc	12.5	350	22800
380 Mc	11.3	320	26400
420 Mc	11.3		upon request

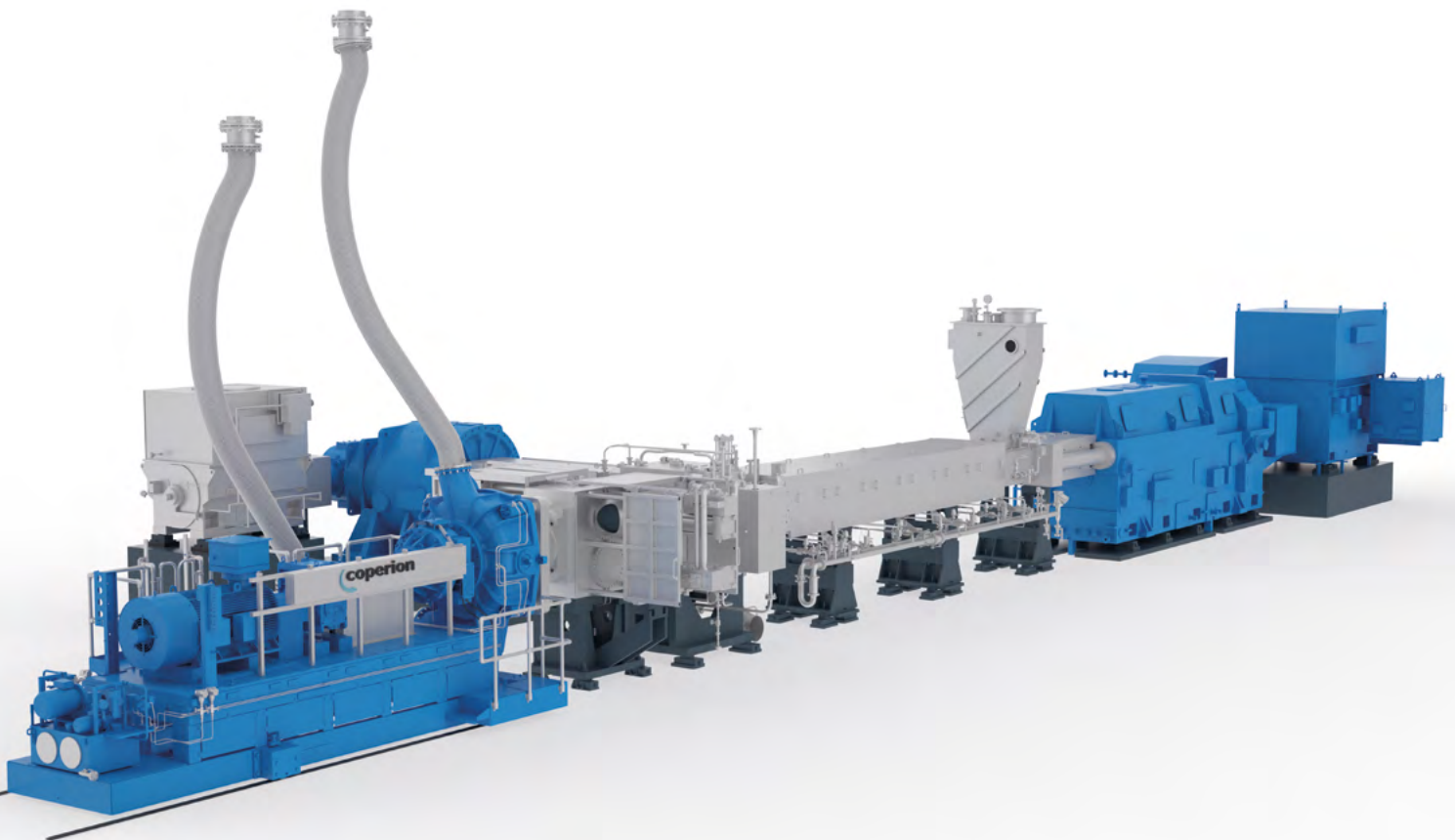

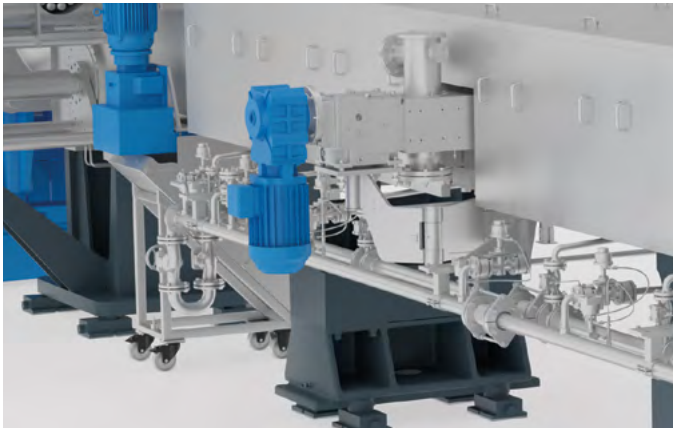

› ZS-EG SIDE DEVOLATILIZATION UNIT

With its large free cross section for devolatilization, the ZS-EG reliably maintains the melt in the process section even at maximum specific torque. Throughput increases and product quality are considerably improved.

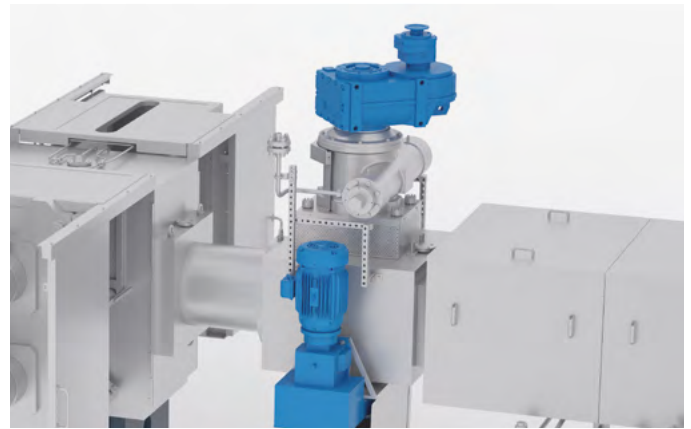

› DAV (STANDARD AND NEW VERSION)

The DAV allows for smooth start-up of the equipment, including purging out old, degraded material to the ground. It avoids screens being blocked or contaminated by black specs. The integration of a butterfly valve allows for individual adjustments during operation. Thanks to the DAV, single and two speed machines can be modified according to quality and temperature treatment requirements. The number of operators required for start-up can be reduced and safety can be increased with a DAV. The new, upgraded version of the DAV, the DAV-XT, features some design changes allowing for higher throughputs and providing lower pressure losses. All DAVs can be equipped with a cutting device in order to make handling of purged polymer as easy as possible.

› EXTRUDER DRIVE CONCEPTS

Coperion offers the most innovative drive concepts. Huge motor power requirements can be split between two smaller motor sizes for flexibility in power layout. The highest energy efficiency is achieved with a fixed speed primary drive motor and a variable speed secondary drive motor to allow the optimal screw speed for different polymers and rates.

DRIVE OPTIONS

- › Single fixed speed
- › Two fixed speed (for two screw rpm)
- › Fixed speed + variable speed (for variable operation window)
- › Variable speed (for full variable screw speed)

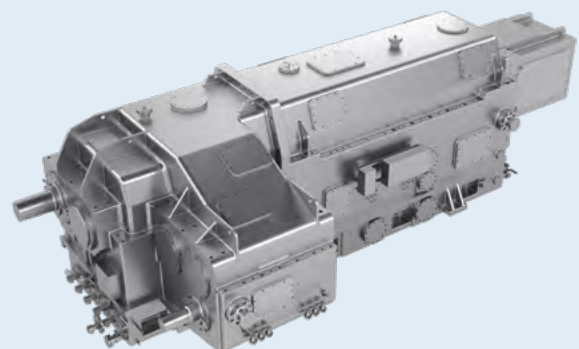

➤➤ Extrusion technology.

➤ MP MELT PUMP

Use of a melt pump is necessary in individual cases for processing and pelletizing polyolefins. It ensures pressure buildup for the melt filtration and pelletizing at a very low introduction of energy. Both Coperion and third-party melt pumps can be integrated into Coperion polyolefin production systems.

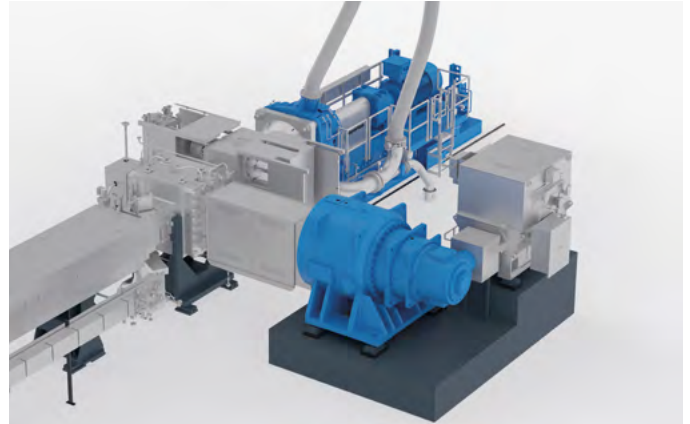

➤ SWZ SCREEN PACK CHANGER

Coperion's SWZ screen pack changer is designed specifically for melt filtration in high-performance production systems. The screen packs can be changed during operation without interrupting or reducing production.

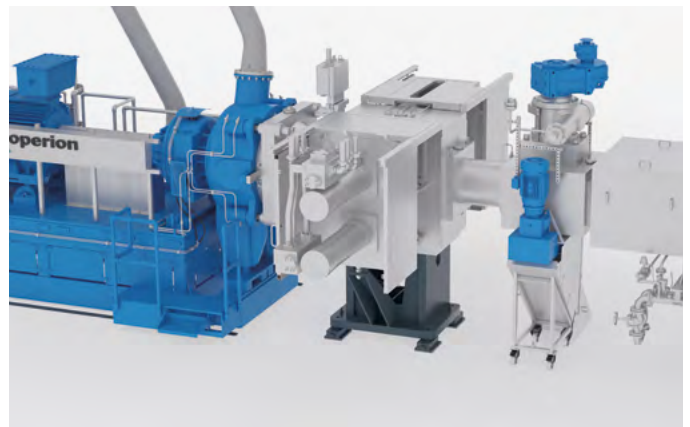

➤ UG UNDERWATER PELLETIZER

Coperion's UG underwater pelletizer is suitable for pelletizing most thermoplastics. Its optimized flow channels ensure a gentle pressure build-up before pelletizing. It achieves maximum throughput rates thanks to the large number of bores per die plate size.

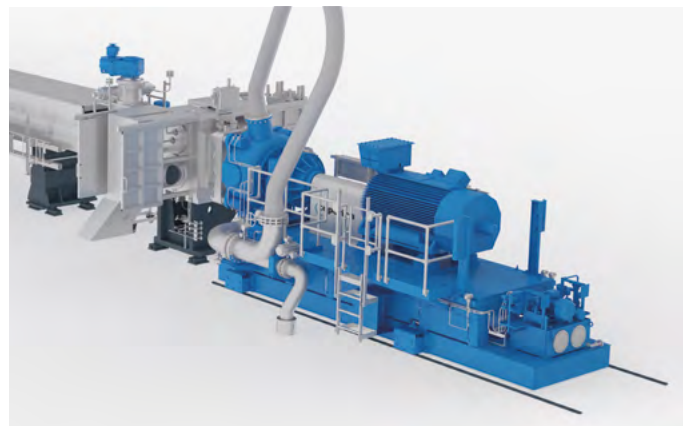

MP melt pump	Throughput rate [t/h]	Cooling	
		Shaft cooling	Shaft-bearing cooling
280	8-22	✓	✓
360	15-42	✓	✓
450	25-75	✓	✓
500	35-100	✓	✓
560	50-135	✓	✓

SWZ screen pack changer	Permissible melt pressure upstream of screen [bar]	Max. throughput rate [t/h]
1900	350	15
2700	350	20
5000	350	30
7000	350	40
9000	350	50
14000	350	65
17000	350	125
21000	350	125
34000*	350	150
42000*	350	150

* improved design for reduced pressure consumption

UG underwater pelletizer	Max. throughput rate PE [t/h]*	Max. throughput rate PP [t/h]*
300	7	12
400	20	25
500	30	35
525		45
550	40	
700	35	50
725		60
750	60	70
775	75	
925		82
950		90
1000	100	
1250	135	

* small UG sizes are used for PP, PE and many other applications

»» The competence to manage complexity and to integrate processes.

The more complicated the processes and structures, the more important it is to have a competent experienced and reliable partner at your side. From reactor discharge through to additive handling in extrusion processes and logistics – Coperion is the number one contact for processing all types of plastics. Our project management team has a wide-ranging scope of engineering skills and know-how at their disposal with all the facets of special knowledge and competence needed for the implementation of both complete plants and individual process stages.

Our global network and the experience of our project managers at all our sites ensure a constant transfer of knowledge which offers you a host of advantages. We provide tailored systems in all sizes, always paying attention to project schedule and the highest standard of quality. Our global assets and project management structure is key to smooth and efficient workflow also in international multi-site projects.

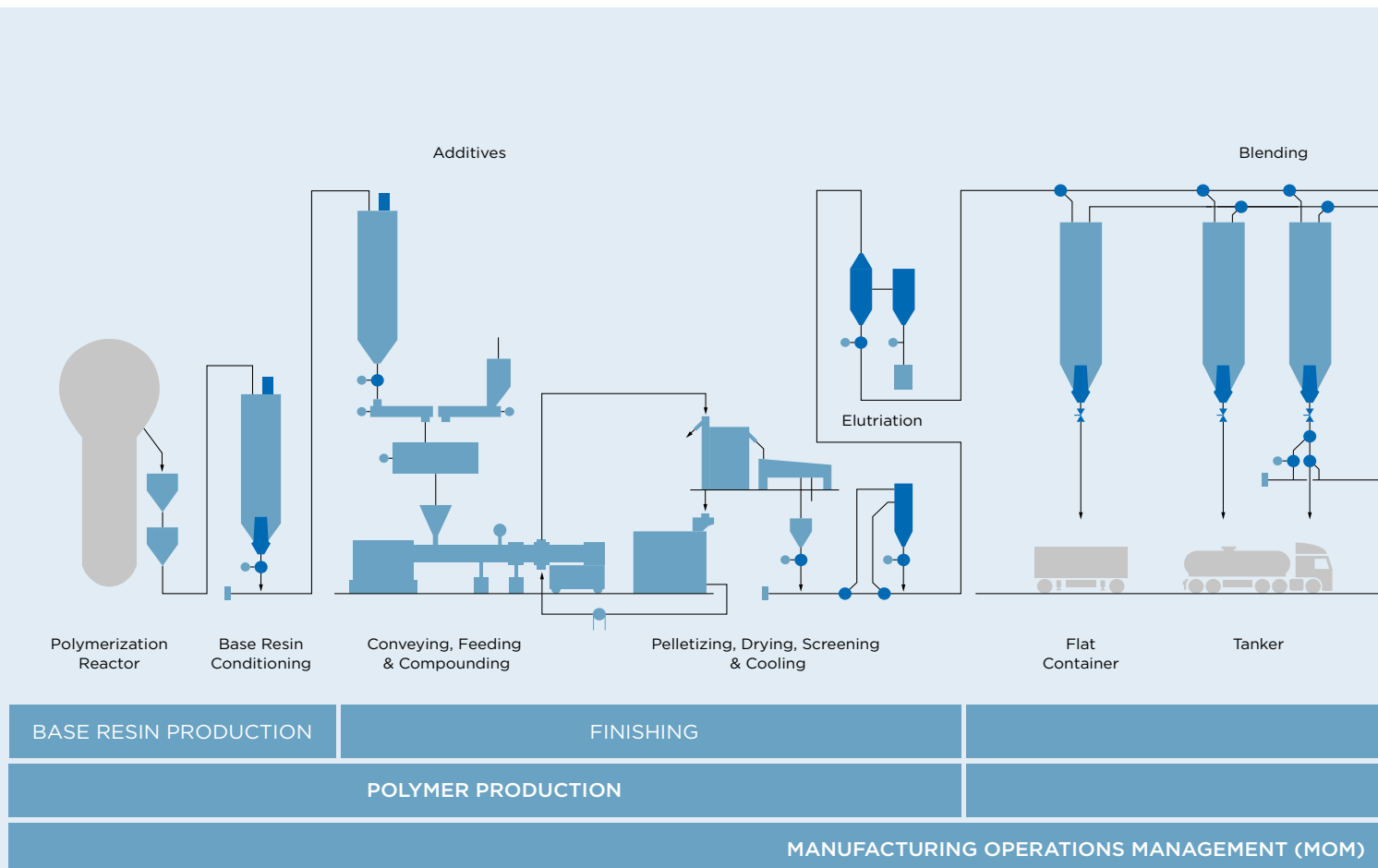

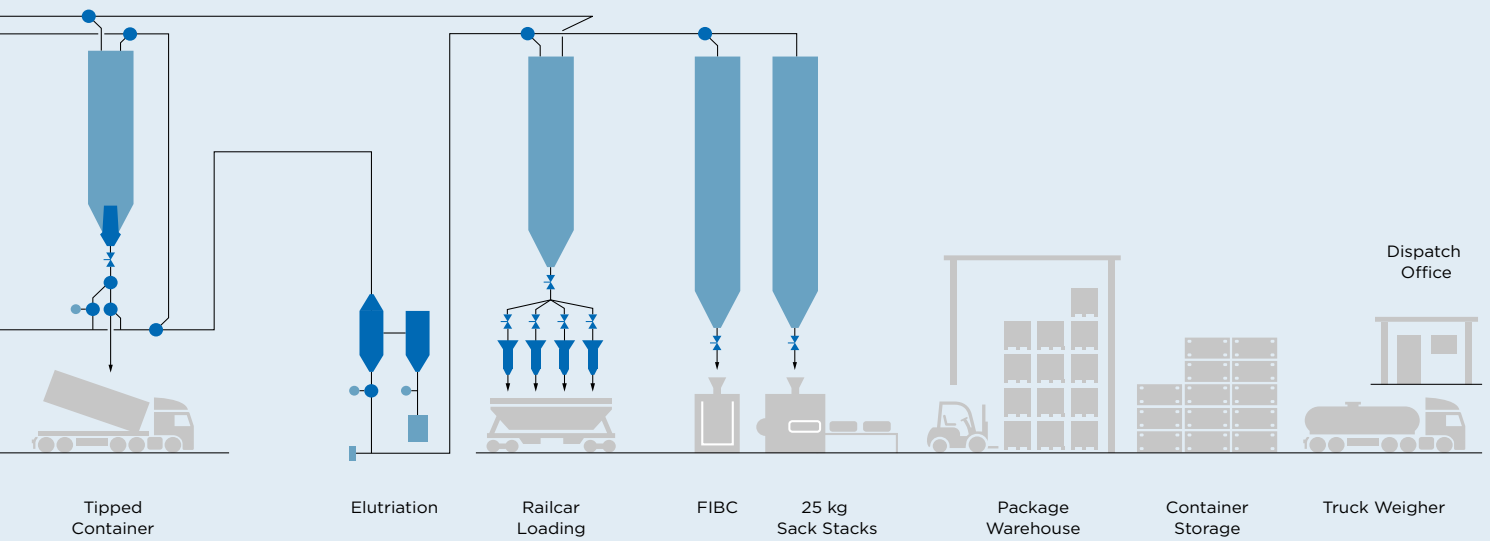

Tipped Container

Elutriation

Railcar Loading

FIBC

25 kg Sack Stacks

Package Warehouse

Container Storage

Truck Weigher

Dispatch Office

BULK STORAGE & LOADING

PACKAGING

FINISHED PRODUCT STORAGE & DISPATCH

LOGISTICS MANAGEMENT

Coperion GmbH

Theodorstrasse 10
70469 Stuttgart, Germany
Tel.: +49 711 897-0
Fax: +49 711 897-3999

Coperion GmbH

Niederbieger Strasse 9
88250 Weingarten, Germany
Tel.: +49 751 408-0
Fax: +49 751 408-200

info@coperion.com
www.coperion.com

> Europe

Belgium, Luxembourg, Netherlands

Coperion N.V.

Industrieweg 2
2845 Niel, Belgium
Tel.: +32 3 870-5100
Fax: +32 3 877-0710

France

Coperion S.a.r.l.

56 boulevard de Courcerin
77183 Croissy-Beaubourg, France
Tel.: +33 164 801 600
Fax: +33 164 801 599

Germany

Coperion GmbH**Germany West Office**

Industriestrasse 71a
50389 Wesseling, Germany
Tel.: +49 2232 20700-10
Fax: +49 2232 20700-11

Coperion Pelletizing Technology GmbH

Heinrich-Krumm-Strasse 6
63073 Offenbach, Germany
Tel.: +49 69 989 5238-0
Fax: +49 69 989 5238-25

Coperion K-Tron Deutschland GmbH

Heinrich-Krumm-Strasse 6
63073 Offenbach, Germany
Tel.: +49 69 8300 899-0
Fax: +49 69 8300 9498

Italy

Coperion S.r.l.

Via E. da Rotterdam, 25
44122 Ferrara, Italy
Tel.: +39 0532 7799-11
Fax: +39 0532 7799-80

Coperion S.r.l.**Milan Office**

Via Achille Grandi 1-3
20091 Bresso (MI), Italy
Tel.: +39 02 241 049-01
Fax: +39 02 241 049-22

Russian Federation, CIS

OOO Coperion

Proezd Serebryakova 14,
Bld. 15, Office 219
129343 Moscow, Russian Federation
Tel.: +7 499 258 4206
Fax: +7 499 258 4206

Spain, Portugal

Coperion, S.L.

Balmes, 73, pral.
08007 Barcelona, Spain
Tel.: +34 93 45173-37
Fax: +34 93 45175-32

Switzerland

Coperion K-Tron (Schweiz) GmbH

Lenzhardweg 43/45
5702 Niederlenz, Switzerland
Tel.: +41 62 885-7171
Fax: +41 62 885-7180

United Kingdom

Coperion Ltd.**Coperion K-Tron Great Britain Ltd.**

Unit 4, Acorn Business Park
Heaton Lane
Stockport, SK4 1AS, United Kingdom
Tel.: +44 161 209 4810
Fax: +44 161 474 0292

> Asia

China

Coperion (Nanjing)

Machinery Co. Ltd.
No. 1296 Jiyin Avenue
Jiangning District
Nanjing 21106, PR China
Tel.: +86 25 5278 6288
Fax: +86 25 5261 1188

Coperion (Nanjing)

Machinery Co. Ltd.
Taiwan Branch Office
7F-2, No.201, Fuxing N. Road
Songshan District
Taipei City 105403, Taiwan
Tel.: +886 2 2547 5267
Fax: +886 2 2547 5980

Coperion International**Trading (Shanghai) Co. Ltd.****Coperion Machinery &****Systems (Shanghai) Co. Ltd.**

3rd Floor, Building B1
6000 Shenzhuan Road
Dongjing Town, Songjiang District
Shanghai 201619, PR China
Tel.: +86 21 6767 9505
Fax: +86 21 6767 9108

Coperion K-Tron (Shanghai) Co. Ltd.

3rd Floor, Building B1
6000 Shenzhuan Road
Dongjing Town, Songjiang District
Shanghai 201619, PR China
Tel.: +86 21 6767 9505
Fax: +86 21 6767 9108

India

Coperion Ideal Pvt. Ltd.

Ideal House, A-35, Sector 64
201307 Noida (U.P.), India
Tel.: +91 120 4299 333
Fax: +91 120 4308 583

Japan

Coperion K.K.

4F, Leaf Square Shin-Yokohama Bldg.
3-7-3, Shin-Yokohama,
Kohoku-ku Yokohama,
Kanagawa 222-0033, Japan
Tel.: +81 45 595 9801
Fax: +81 45 595 9802

Saudi Arabia

Coperion Middle East Co. Ltd.

Street # 327, Sector G, Block 2, Lot # 31
Jubail 2 Industrial City,
Kingdom of Saudi Arabia
Tel.: +966 13 510 4420
Fax: +966 13 510 4421

Singapore

Coperion Pte. Ltd.**Coperion K-Tron Asia Pte. Ltd.**

12 Woodlands Square
#04-74, Woods Square
Singapore 737715
Tel.: +65 641 88-200
Fax: +65 641 88-203

Thailand

Coperion South East Asia Ltd.

Building SW12 No.13/3 Highway Road 3191
Huai Pong Sub-District,
Mueang Rayong District
Rayong 21150, Thailand

> America

South America

Coperion Ltda.

R. Arinos, 1000
RBCA - Royal Business Center
Anhanguera, M6dulo 4
Parque Industrial Anhanguera
06276-032 Osasco - SP, Brazil
Tel.: +55 11 3874-2740
Fax: +55 11 3874-2757

USA, Canada, Mexico, NAFTA

Coperion Corporation

590 Woodbury Glassboro Road
Sewell, NJ 08080, USA
Tel.: +1 201 327-6300
Fax: +1 201 825-6494

Coperion Corporation**Wytheville Office**

196 Appalachian Drive
Wytheville, VA 24382, USA
Tel.: +1 276 228-7717
Fax: +1 276-227-7044

Coperion Corporation**Houston Office**

5825 North Sam Houston Pkwy West
Suite 250
Houston, TX 77086, USA
Tel.: +1 281 449-9944
Fax: +1 281 449-4599

Coperion K-Tron Salina, Inc.

606 North Front Street
Salina, KS 67401, USA
Tel.: +1 785 825-1611
Fax: +1 785 825-8759

Coperion K-Tron Salina, Inc.**Sewell Office**

590 Woodbury Glassboro Road
Sewell, NJ 08080, USA
Tel.: +1 856 589-0500
Fax: +1 856 589-8113

For more information about the worldwide Coperion network, visit www.coperion.com